

SX-9000

FW

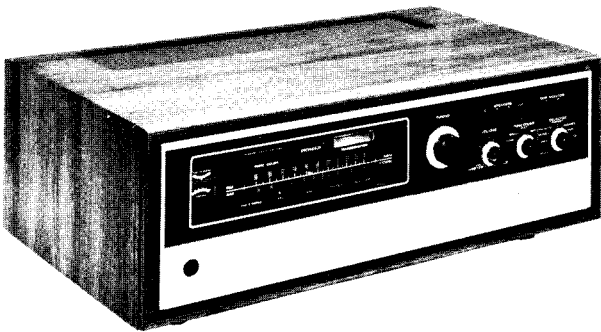

INSTALLATION, OPERATION AND SERVICE MANUAL

Including PARTS LIST, CIRCUIT DIAGRAMS,
TROUBLE SHOOTING AND MOUNTING TEMPLATE.

PIONEER®

FEATURES

A MULTI-PURPOSE, EASY-TO-USE DESIGN

The SX-9000 was designed to give you a high degree of versatility in operation. You can, for example, use two microphones, two tape decks, two headsets with the SX-9000. All controls are rationally placed for easy use. The circuitry is quite advanced, on a par with professional designs.

CLEAN-LINED, CONTEMPORARY APPEARANCE

The SX-9000 looks good, too. The front incorporates a folding panel that adds to its distinctive design. When in operation, the smoked glass dial window lights up with subdued illumination, and the source also lights up for quick identification.

HIGH PERFORMANCE TUNER

The SX-9000 employs the latest circuitry, including FET and IC's. The result is a professional receiver of exceptional sensitivity and stability.

PRE-SET TONE COLORS

In addition to the normal bass and treble controls, there is a 4-position tone color selector knob. This provides quick switching from "flat" to "soft", "bass" or "vivid". These characteristics are symbolized in an illuminated window in the dial face.

TAPE-TO-TAPE MONITORING

Two buttons on the front panel allow easy, one-touch monitoring of tapes "A" or "B" when you use the SX-9000 to copy directly from one tape to another.

FOOLPROOF MICROPHONE USE

When either microphone knob is set to OFF, the unit operates in parallel to provide monophonic signals for both speakers without having to set the mode switch.

REVERBERATION EFFECT

Also included is a reverberation effect knob. The degree of "echo" is easily read in the "Reverberation" window in the dial face.

SPECIAL "OVERLOAD PROTECTION"

You can play up to three different pairs of speaker systems through the SX-9000 in combinations A, B, C, A+B, A+C, B+C. If all three are accidentally turned on, however, the "Overload Protection" goes into action and the speakers are automatically shut off.

EARPHONE VERSATILITY

Because the SX-9000 has two "earphones" output jacks, two people may listen simultaneously with earphones without having to go through an accessory junction box.

LINE VOLTAGE SELECTION AND FUSE

SWITCHING LINE VOLTAGE SETTING AND FUSE

To remove the fuse, turn the fuse cap located on the line voltage selector switch in the direction indicated by the arrow. Then remove the fuse plug from the unit. Put the fuse plug back so that the proper line voltage marking can be seen through the cut on the edge of the plug. Whenever the position of the selector switch is changed, check the rating of the fuse. A 1.5-ampere fuse is to be used for either 220V or 240V operation and a 3-ampere fuse for 110V, 120V or 130V operation. If the rating of the fuse is correct, replace cap.

FUSE REPLACEMENT

If the fuse blows, remove the fuse cap and replace the fuse with a new one.

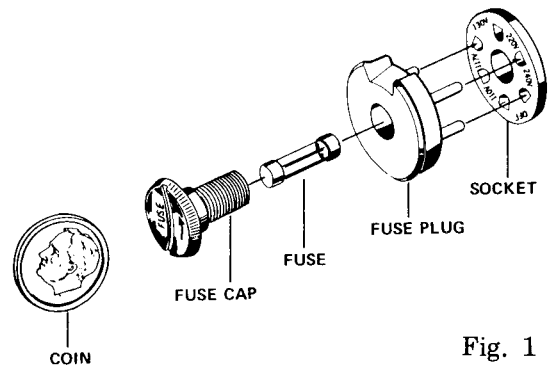

Fig. 1

Take off the fuse cap by turning it with a coin, etc. in the direction indicated by the arrow mark.

STEREO SYSTEM

The SX-9000 is general-purpose stereo amplifier. Connect it to the speaker systems (two to six), turntable, tape recorder, etc., which are separately available.

INSTALLATION

When installing your stereo system, check the following points.

- The place should be well-ventilated, and free from dampness and dust.
- The units should not be exposed to direct sunlight.
- The units should not be placed near radiators or other heating units.
- The place should be substantial and roomy enough for the installation, when installing the unit on a shelf.

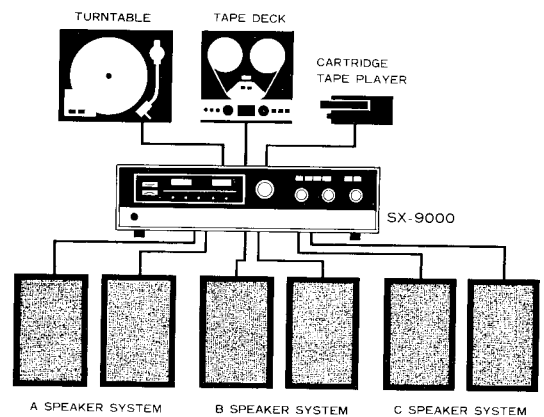

Fig. 2

A WORD ABOUT ROOM ACOUSTICS

The quality of reproduced sound varies according to the size and shape of the room, the materials of walls, floor and ceiling and the amount and arrangement of furniture. Too harsh or "bright" a sound usually results from too many hard reflecting surfaces, and/or too low a ceiling. This condition is improved by having ample carpet area or covering the wall (especially that facing the speakers) with a thick curtain.

On the other hand, too many absorbing surfaces will tend to "soak up" the sound, resulting in a certain "deadness".

Furniture may be rearranged to provide irregular reflection of the sound. In any event, the true stereo effect is lost if the two speaker systems are placed too far apart. This may be corrected by angling them slightly toward each other or reducing the distance between them.

SPEAKER SYSTEM CONNECTIONS

- First remove the speaker connector plugs from the accessories bag and then connect the speaker leads as shown in Fig. 3. Be sure to match the speaker and plug polarities.
- After the plugs are connected, insert the one for the right channel in the left side of the SPEAKER OUTPUTS (A) panel on the rear of the unit. Connect the left channel to the right side of this panel as shown in Fig. 3. (Refer also to the connection diagram on Page 4.)
- If you have one (or two) more speaker system(s), connect them in the same way, using the B (and C) terminals.

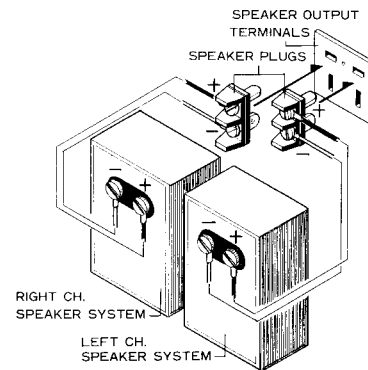

Fig. 3

ANTENNA AND GROUND CONNECTIONS

When using the SX-9000 at a place of low field strength or distant from the station, select the most suitable FM and AM antennas as follows, and the efficiency of any antenna depends on its height more than its length.

FM ANTENNA

- Reception is easier if the building is primarily of wood and is near the FM station, in this case, use the accessory T-type indoor antenna. Unfold the horizontal section of the antenna to its full length, and determine the best direction for the antenna while actually receiving an FM broadcast program. Attach the horizontal section to a wall or other place in the determined direction. (See Fig. 4.)
- When using the SX-9000 at a relatively long distance from the station, or within a building or home with relatively thick walls, or vicinity of tall buildings, erect an FM outdoor antenna, and connect it to the FM antenna terminals as shown in Fig. 5.

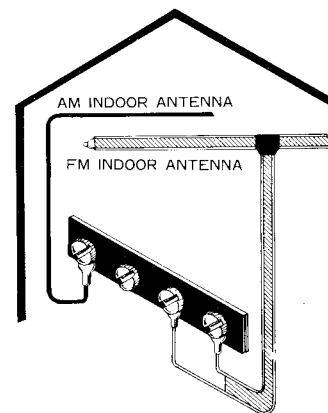

Fig. 4

AM ANTENNA

- If your house is located in area relatively close to the AM station, the ferrite loopstick antenna provided on the back of the SX-9000 will be sufficient for reception of AM broadcast program. The antenna is directional it should be moved about while listening to a station and set at the position which provides the best reception. (See Fig. 6.)
- If the loopstick antenna does not provide sufficient sensitivity for reception and static is noticeable, put the furnished antenna wire on the wall and connect one end of the wire to the AM antenna terminal. (See Fig. 4.)
- If you want reception from a distant AM station, you may have to set up an AM outdoor antenna. In such a case, connect one end of the AM outdoor antenna to the AM antenna terminal. (See Fig. 5.)

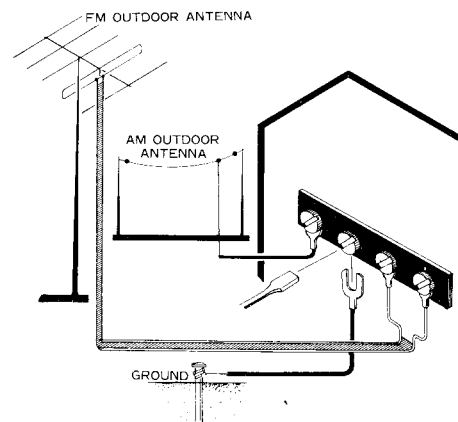

Fig. 5

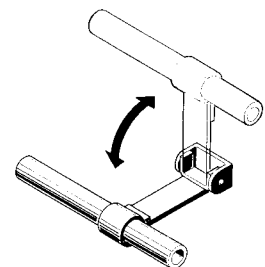
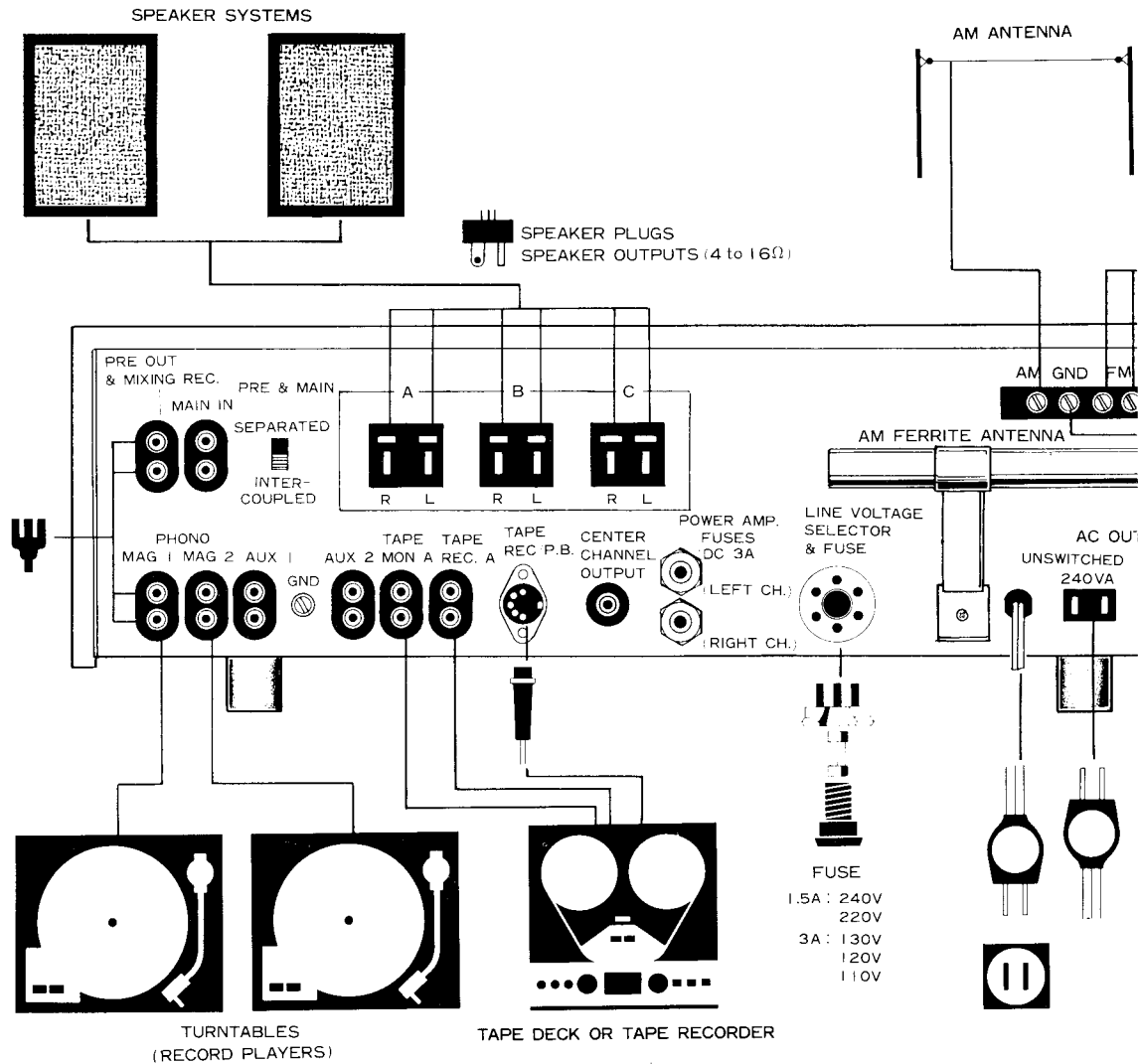

Fig. 6

CONNECTION DIAGRAM

NOTE :

If connecting one set of speaker systems to speaker output terminal the speaker of each channel should be 4 to 16 ohms ; however, both output terminals (A, B and C speakers) to two speaker systems the of each channel, 8 to 16 ohms.



GROUNDING

The SX-9000 will provide stable performance whether grounded or not. In rare case, however, grounding may help. If so, connect a wire from the GND terminal to a water pipe or balcony, fastening it **FIRMLY**. Never use a gas pipe as a ground.

MICROPHONE CONNECTION

Insert the plug on the microphone cord into either one of the MIC jacks on the front panel of the unit. Use both jacks when you wish to employ two microphones at the same time. •

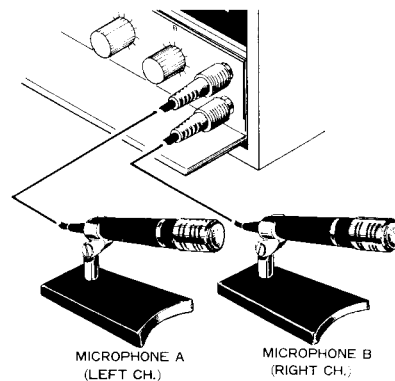

Fig. 8

TURNTABLE

- If the turntable cartridge, 1 terminal crystal capacitor. Connect the right terminal to the left terminal either terminal.
- A second terminal used, connect to the right terminal.
- If a turntable is used, either separate terminals.
- Some turntable terminals with the...

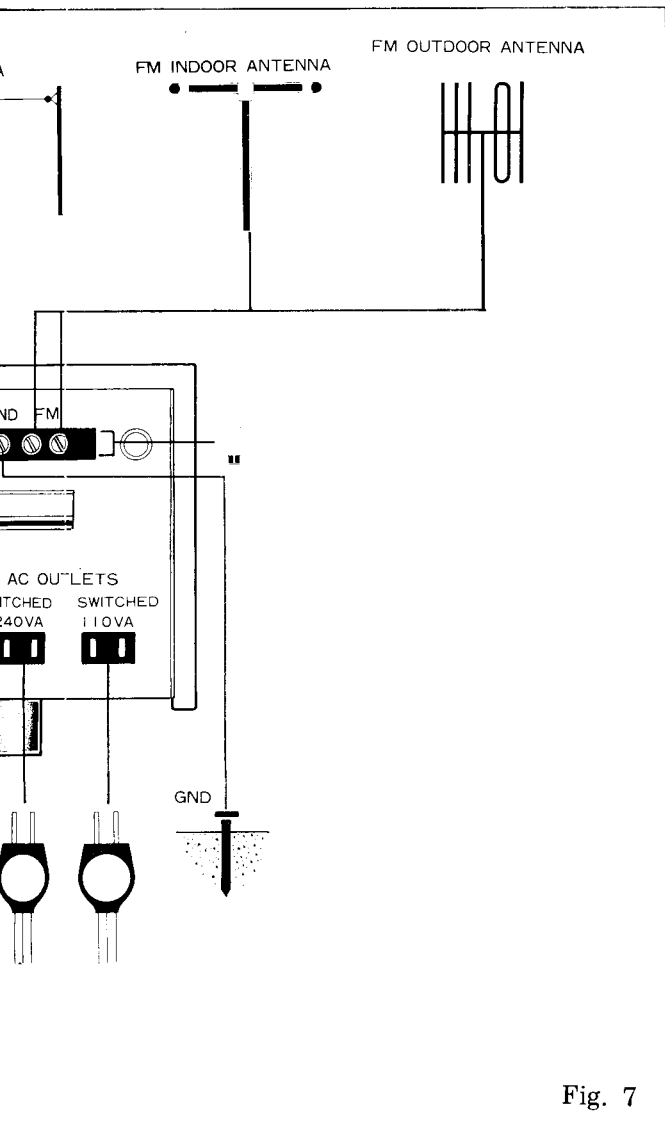

Fig. 7

TURNTABLE CONNECTION

The turntable is equipped with a moving-magnet type cartridge, connect its output cords to the PHONO MAG terminals on the rear of the unit. If the turntable has a crystal cartridge, connect it to the AUX 1 terminals.

Connect the left channel cord to the upper terminal, the right to the lower. If the cartridge is of monophonic type, either terminal will do.

If a second turntable with magnet type cartridge is to be used, connect its cords to the PHONO MAG 2 terminals.

If a turntable with a moving-coil (MC) cartridge is to be used, either a matching transformer for MC cartridge or a pre-amplifier head amplifier must be employed.

If the turntable output cord plugs do not match the terminals of this unit. In such a case, replace the plugs with the spares provided in the accessories bag.

TAPE DECK (RECORDER) CONNECTION

- A tape deck connected to this unit must have a record/playback preamplifier built-in. PIONEER's models T-600 and T-500 feature characteristics ideally suited to the SX-9000.
- The connected tape recorder should also have output terminals for tape recorder connection (LINE OUT) or tape monitor terminals.

CONNECTION FOR TAPE RECORDING

Connect this unit's TAPE REC terminals to the signal input (LINE IN) terminals of the tape deck. Use the cords provided with the deck. The upper terminal is for the left channel, the lower for the right. If the tape deck is of monophonic type, use the CENTER CHANNEL output terminal instead.

CONNECTION FOR TAPE PLAYBACK (OR MONITOR)

Connect the LINE OUT or TAPE MONITOR terminals on the tape deck to the TAPE MON terminals on this unit. Connection is done in the same way as described in the above paragraph.

USE OF RECORD/PLAYBACK CONNECTOR

The tape deck has a DIN type record/playback connector, all recording and playback connections can be made by means of this one (optional) cord. Plug one end into the TAPE REC/P.B. connector on this unit and the other into the corresponding connector on the tape deck. In this case no other connection cords are necessary.

CONNECTION FOR MIXED RECORDING

Connect the tape deck input terminals and this unit's PRE OUT & MIXING REC terminals. Connection is made in the same way as outlined above.

CONNECTION WHEN USING TWO TAPE DECKS (RECORDERS)

When using two tape decks, for example, when you wish to edit an already-recorded tape or practice along with a recorded concert, etc., and then hear the results, connect the second tape deck to the TAPE MON B and TAPE REC B jacks on the front of the SX-9000. These jacks take 1/4" standard phone plugs.

FRONT PANEL FACILITIES

POWER

Push once to switch on the power, once again to turn it off.

PHONES JACKS

These phones jacks for stereo headset(s). The two jacks (A, B) are available for connection with two stereo headsets.

BASS

Turn this knob to the right to accentuate bass tones, to the left to reduce them. Set the knob at its center position for flat response.

TREBLE

Use of this knob is similar to that of the BASS knob.

REVERB

This is the reverberation adjustment knob. Turn it to the right to increase reverberation, to the left to reduce it.

FILTER

LOW: Use this filter to cut out low-frequency interference, such as motor rumbling or hum.

HIGH: Use this filter to cut out high-frequency interference, such as that from fluorescent lights.

FM MUTING

This switch is used to suppress much noise between FM stations when tuning. In a fringe area, however, this switch should be kept off because it may suppress the desired station signal at the same time.

LOUDNESS

At reduced volume the ear's sensitivity to extremely low and high frequencies is reduced. This switch compensates for that phenomenon by emphasizing these frequencies. At normal or high volumes this switch should be kept off.

TAPE MON B JACK

This jack is for connecting to the LINE OUT terminals of a tape deck or tape recorder. It is designed to accept a 3-P type plug.

TAPE REC B JACK

For connecting to the LINE IN terminals of a tape deck (recorder). Allows recording of another program source or tape for editing.

TUNING INDICATOR

When selecting pointer of the tuning meter as possible.

For an FM broadcast station, tune in the way. Precision tuning that the dial pointer indicates.

TUNING

This knob is used to tune the tuning meter.

TONE COLOR

INDICATOR

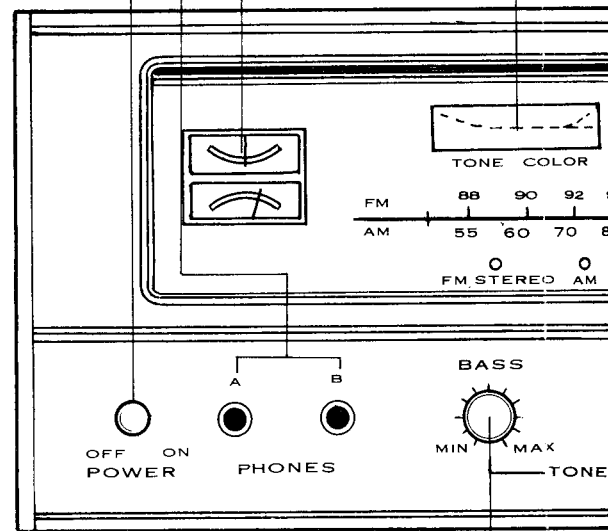

BALANCE CONTROL

Used to adjust the balance of the left and right channels for a balanced stereo channel sound.

MODE SWITCH

Controls the stereo mode of the unit as follows:

REV: Stereo reverse

ST: Normal

LT: Left channel speaker

RT: Right channel speaker

L+R: Left and right channels to both speakers

TUNING INDICATOR

When selecting an AM broadcast, tune so that the dial pointer of the lower meter deflects as far to the right as possible.

When tuning an FM broadcast, use the lower meter in the same manner. Precision FM tuning is also possible by adjusting so that the dial pointer of the upper meter is centered.

TUNING

The tuning knob is used to locate AM or FM stations. Watch the tuning meter(s) for more precise tuning.

TONE COLOR INDICATOR

REVERBERATION INDICATOR

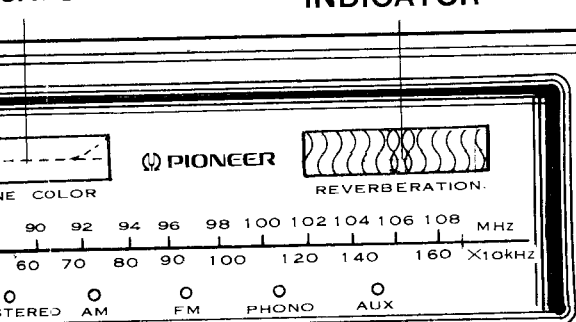

SOURCE VOLUME

This knob is used to adjust the volume of AM and FM broadcasts, record play and tape playback. It is also used to balance the program source signal level during mixed recording with a microphone.

MASTER VOLUME

Turn this knob to the right to increase the volume from the speakers. If this knob is turned down all the way no sound will come from the speakers, even though the SOURCE and MIC LEVEL volume controls are turned all the way to the right.

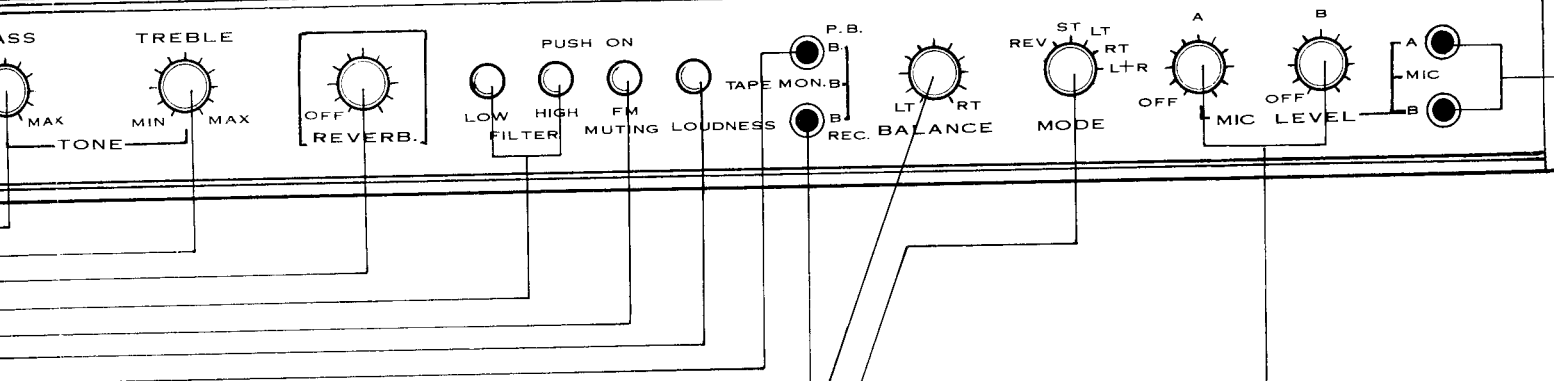

BALANCE CONTROL

Used to adjust the stereophonic balance between left and right channels. Turning to the left strengthens the left channel sound; to the right, the right channel.

MODE SWITCH

Controls the stereo and mono output functions of the receiver as follows.

- REV: Stereo, with right and left channel signals reversed.
- ST: Normal stereo.
- LTR: Left channel signal fed to both left and right speakers.
- RT: Right channel signal fed to both left and right speakers.
- REV: Left and right channel signals mixed, then fed to both left and right channel speakers.

MIC LEVEL CONTROLS

Control the microphone signal input level. Control A is for a microphone connected to MIC JACK A, and Control B for MIC JACK B. Turning either to the right increases the signal. Microphones can be used at any time, for mixing with another sound source, such as a record or recorded tape. When a microphone is not being used, that control should be turned all the way to the left (off).

NOTE: When only one microphone is used, its signal is monaurally fed through both left and right speakers, regardless of which jack is used. When two microphones are used, however, the one connected to jack A broadcasts through the left speakers, while the one connected to jack B is heard through the right.

SPEAKERS

These switches turn the various speaker systems on and off. Push each button once to turn it on, once again for off. Pushing the A button will cause the sound to be reproduced from the speakers connected to the SPEAKER A terminals. The B and C buttons control their corresponding terminals on the rear of the unit.

NOTE: Only two speaker systems can be used at the same time (i.e., A+B, B+C, or A+C). If all three speaker buttons are pushed at the same time, no sound will be reproduced.

If you wish to shut off all speaker sound, simply press the OFF button.

TONE COLOR

This switch is for selecting the particular tone to suit your mood or the music being heard.

VIVID: Emphasizes highs and lows for more sound clarity

BASS: Emphasizes bass tones.

FLAT: Flat, untempered tone.

SOFT: High tones relatively softened.

TAPE MONITOR

Depress this button to monitor a recording; press it again and it shuts off. During record or tape play, or when listening to a broadcast, leave this switch off. Turning it on automatically switches off the speakers. This button is intended to aid in checking recording or editing conditions.

There are two TAPE MONITOR jacks, A and B, on the rear (A) and front (B) of this unit, and these two buttons correspond to them. Button A directs the signal through jack A, and button B through jack B.

SELECTOR

This switch is for choosing the program source.

AM: For receiving AM broadcasts.

FM MONO/WIRELESS: For FM monophonic broadcasts, or for broadcasting the signal from a wireless FM microphone.

FM AUTO: For automatic switchover between FM mono and stereo broadcasts.

PHONO 1: For playing records on a turntable connected to the PHONO 1 terminals.

PHONO 2: Same as above, for PHONO 2 terminals.

AUX 1: For playing signals fed to the AUX 1 terminals.

AUX 2: Same as above, for AUX 2 terminals.

MIC JACK A, B

Plug a microphone used into one of these jacks. Two microphones can be used at the same time.

RECEPTION OF FM

1. Set the SELECTOR switch to FM STEREO.
2. Turn the MUTING switch on (unless the signal strength is very low—then leave it off).
3. Tune in the desired station while watching the TUNING meters.

Best reception is obtained when the dial pointer of the lower meter deflects as far to the right as possible for that station, while that of the upper meter is centered.

If the broadcast is stereo, the FM Stereo indicator will light up. It remains unlit if the broadcast is monophonic, and the set automatically switchover for monophonic reception.

4. After tuning is complete, slowly turn up the VOLUME SOURCE and MASTER knobs until the proper level is achieved.

Then adjust the BASS, TREBLE, TONE COLOR and other controls for the most pleasing sound.

5. To increase reverberation, turn the REVERB knob to the right.

For FM reception located far away from the station, or when external noise is high, reception can be improved by setting the SELECTOR to FM MONO. In this case, however, stereo programs will be received as monophonic.

RECEPTION OF AM

1. Set the SELECTOR switch to AM.
2. Tune in the desired station while watching the lower TUNING meter. Tune so that the dial pointer deflects as far to the right as possible for that station.
3. After tuning is complete, slowly turn up the VOLUME to the desired level, then adjust the BASS, TREBLE and TONE COLOR controls.
4. To increase reverberation, turn the REVERB knob to the right.

If noise is extremely high during both FM and AM reception, the problem could be in the antenna and ground. Reread the section, ANTENNA CONNECTION AND GROUNDING, page 3.

LISTENING TO RECORDS

1. Set the SELECTOR switch to PHONO 1 or PHONO 2.
To use the turntable connected to the PHONO 1 terminals, set to PHONO 1, for that connected to PHONO 2, set to PHONO 2.
2. If the record is monophonic, set the MODE switch to either L or R.
3. Adjust the VOLUME, BASS, TREBLE and TONE COLOR controls.
4. To increase reverberation, turn the REVERB knob to the right.

USING MICROPHONES

The SX-9000 permits the use of two microphones at once, for such purposes as recording a concert in stereo; even performances or dramas in large theaters can be efficiently recorded.

1. Turn the VOLUME - SOURCE knob all the way down if microphone recording only is desired. If mixed recording, combined with music from a record, etc., is desired, set the SOURCE knob to the best level.
2. The MIC LEVEL A knob controls the input from a microphone plugged into MIC jack A; knob B controls jack B. Turn either of these knobs to the right to increase input signal strength. Adjust the level while watching for "howling" (acoustical feedback of the speaker signal through the microphone). If this occurs, reduce the volume or separate the microphone(s) and speakers. If only one microphone is used, plug it into either jack. If setting the MIC LEVEL for another jack not being used to OFF, the sound will be reproduced from both speakers.

NOTE: When adjusting the MIC LEVEL control, be careful not to cause howling.

Howling is of course unpleasant to hear, but it can also damage the VU meter of your tape recorder or deck during recording.

3. If two microphones are used, the one connected to jack A will broadcast over the left channel, B the right. If you wish to use only one of these microphones at any time, turn the unused microphone level control off. Then the microphone used will broadcast over both channels.

USING TAPE DECKS AND TAPE RECORDERS

As shown in Fig. 9, signals heard from the speakers are normally fed to the SX-9000 TAPE REC A and B terminals. When recording, set the SELECTOR and MODE switches to your program source. Refer to the sections on Listening to Broadcasts and Listening to Records. Recording signals cannot be regulated by the SX-9000 VOLUME, BASS, TREBLE and TONE COLOR switches. These must be adjusted by the recording level control on the tape deck/tape recorder.

NOTE: When using mono tape recorders, either the left channel signal or the right channel signal may be recorded, but not both. The CENTER CHANNEL terminal should therefore be used.

TAPE MONITOR

With 2-head and 3-head type tape recorders fitted with monitor mechanisms, turning the TAPE MONITOR switch ON during recording has the following effects (if recording and playback heads are first connected): With the 2-head type, signals fed to the recording head can be monitored; with the 3-head type, signals can be monitored immediately after recording. (See Fig. 9.)

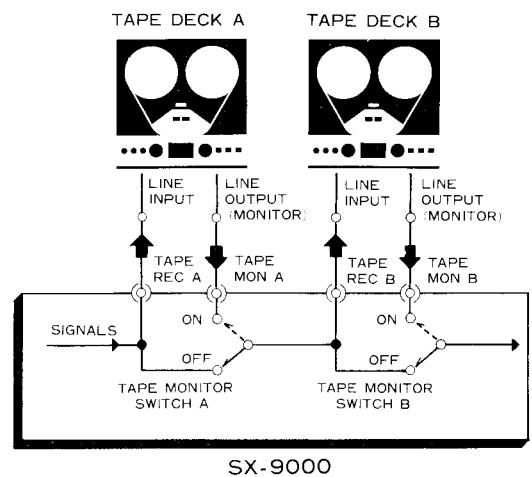

Fig. 9

PLAYBACK

- Turn TAPE MONITOR SWITCH A or B ON and adjust the VOLUME, BASS, TREBLE and TONE COLOR switches to the desired levels.
- When TAPE MONITOR SWITCHES A or B are turned ON, the position of the SELECTOR becomes immaterial.

MIXED RECORDING

When using a microphone in mixed recording, connect the tape deck to the PRE OUT terminal and adjust the volume of the microphone with the MIC LEVEL knob while listening to the record or broadcast. Do not turn this knob too high as this will result in howling and may damage the VU meter of the tape deck.

EDITING RECORDING TAPES

By using two tape decks and re-recording only certain parts of a tape, you can edit old tapes taken from FM broadcasts, etc. and obtain a brand-new tape containing only your favorite recordings:

1. As shown in Fig. 10, place the old tape or mother tape on TAPE DECK A and turn TAPE MONITOR SWITCH A ON.
2. Place the new tape on TAPE DECK B.
3. Playback is performed on TAPE DECK A and recording on TAPE DECK B.
By turning TAPE MONITOR SWITCH B ON and OFF you can monitor the recording. Be sure not to turn TAPE MONITOR SWITCH A OFF.

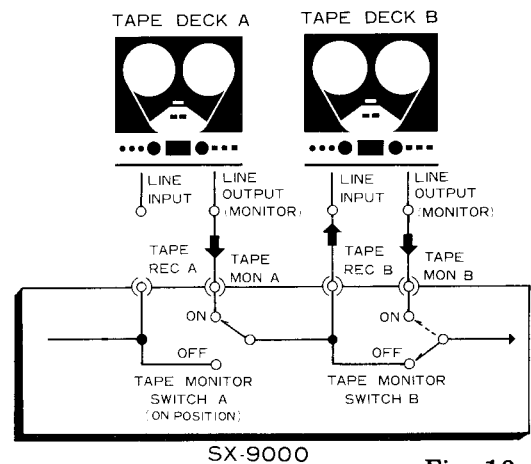

Fig. 10

YOU CAN ALSO USE YOUR SX-9000 AS FOLLOWS

MULTICHANNEL AMPLIFIER SYSTEM

By using an ELECTRONIC CROSSOVER NETWORK (PIONEER MODEL SF-700) and one or two POWER AMPLIFIERS, you can build a high-quality multichannel amplifier system.

- a. Set the PRE & MAIN switch on the rear panel of the SX-9000 at the SEPARATED position.
- b. Connect the PRE OUTPUT terminal of the SX-9000 and the CROSSOVER NETWORK INPUT terminal. Also connect the CROSSOVER NETWORK LOW-RANGE OUTPUT terminal and the MAIN INPUT terminal of the SX-9000.
- c. For MID-RANGE and HIGH-RANGE a separate POWER AMPLIFIER must be used.

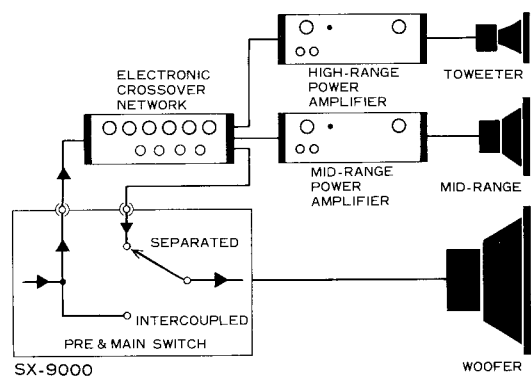

Fig. 11

3-D STEREO SYSTEM

By connecting a POWER AMPLIFIER with a low-pass filter of 150 - 250Hz cut-off frequency to the CENTER CHANNEL OUTPUT terminal in the rear panel, you can set up a 3-D stereo system.

CONDITIONS FREQUENTLY MISTAKEN FOR MALFUNCTION

Noise: There are a variety of noises relating to the operation of a hi-fi unit. These are generally divided into two types; (1) the unit is faulty (a transistor or part has deteriorated) and (2) an external source of noise is adding noise to the unit. When a hi-fi unit produces an unpleasant noise, it is often assumed that the unit is faulty, but statistical records indicate that the majority of noises produced in hi-fi acoustic units result

from external sources of noise. Due to the inherent high amplifier and reproduces extraneous noises into definite output noise. If your receiver produces a noise, check according to the following table and trace out the source of noise for the appropriate corrective action.

	Symptom	Suspected Source of Noise	Diagnosis and Remedy
When Listening to Broadcast	Continuous or intermittent noise like jJJJJJ or zzzzzz.	<ul style="list-style-type: none"> ● Static (lightning) ● Fluorescent lamp, motor, or thermostat may be in use in house or in the vicinity of the house. 	In many cases, it is very difficult to remove the source of noise. In order to make the radio input larger than the noise level, set up a good outdoor antenna and make a complete grounding.
	When a station is tuned in, hum is mixed in the program.	<ul style="list-style-type: none"> ● Poor fluorescent lamp, motor, or electric heater may be in use in house or near the house. 	Reversing the line plug may occasionally alleviate this noise problem. Usually it is very difficult to eliminate the noise.
	Hissing sound noise in AM (medium wave) reception.	<ul style="list-style-type: none"> ● The frequency of an adjacent station is interfering with that of the station being tuned in (10kHz beat interference). ● TV set is on in the same house with the receiver. 	Impossible to remove such interference. If the cause of such noise is in the TV set, increase the distance between the TV set and receiver.
	Static noise (in particular, when automobiles run close to the house).	<ul style="list-style-type: none"> ● White noise generated from automobile engines. ● Radio frequency sewing machine or welding machine being used near your house. 	In an area surrounded by hills or high buildings, the FM input signals are very weak. Thus the noise limiter in the circuit loses its function. Set up an outdoor FM antenna having many reflector elements.
	Reception of FM stereo program contains more noise than FM mono program.	<ul style="list-style-type: none"> ● Note that the service area covered by an FM stereo broadcast is about 50% of that of a regular mono broadcast. 	Increasing FM input signal may alleviate this problem. Use an exclusive FM outdoor antenna instead of the indoor T-type antenna.
When Playing Records	Hum or buzz. When switched to radio reception, the noise disappears.	<ul style="list-style-type: none"> ● Poor connection of shielded wire. (a) ● Jack connection is loose. (b) ● Line cord or fluorescent lamp is near the shielded wire. (c) ● Poor grounding. (d) ● Ham transmitting station or TV transmitting station is near your house. (e) 	Correct the conditions stated in (a), (b), (c) or (d). In case of (e), report it to an official activity.
	Output tone quality is poor and mixed with noise. Treble is not clear.	<ul style="list-style-type: none"> ● Stylus is worn out. (a) ● Record is worn out. (b) ● Dust adheres to stylus. (c) ● Stylus is improperly mounted. (d) ● Stylus pressure is not proper. (e) ● The TREBLE level is too high. 	Check (a) through (e) and correct the condition. Lower the TREBLE level.

Watch for the following conditions; these are also apt to be mistaken for malfunction.

	Symptom	Suspected Source of Noise	Diagnosis and Remedy
	Power is not turned on although the power switch is set to ON.	<ul style="list-style-type: none"> ● Fuse blows. (a) ● Line plug is loose. (b) 	Check (a) and (b) and correct the condition.
	In playing a record, increasing the volume causes howling.	<ul style="list-style-type: none"> ● Distance between the turntable and the speakers is too short. ● The place on which the turntable or speakers are set is unstable. 	Change the distance or rearrange the installation increase of the unit and speakers. (Installing the turntable on a firm, solid stand may alleviate this problem.) Do not enhance the BASS sound level excessively.

SPECIFICATIONS

SEMICONDUCTORS

Audio Section

Transistors	41
Diodes	11

Tuner Section

IC's	5
FET	1
Transistors	12
Diodes	11

AUDIO SECTION

Music Power Output	8 Ω 150 watts total (IHF rating) 4 Ω 240 watts total
Continuous Power Output (Each channel driven)	8 Ω 62w/62w (1kHz) 4 Ω 85w/85w (1kHz)
Continuous Power Output (Both channel driven)	8 Ω 50w + 50w (1kHz) 4 Ω 60w + 60w (1kHz)
Harmonic Distortion	Less than 0.5% (at 1kHz, continuous power output)
Damping Factor	30 (at 8 Ω , 1kHz)
Frequency Response	10Hz to 35kHz, \pm 1dB
Power Bandwidth	10Hz to 35kHz (IHF rating)
Hum and Noise	PHONO MAGmore than 80dB AUXmore than 100dB
Sensitivity and Impedance (at 1kHz, continuous power output)	PHONO MAG (1,2)2.5mV, 50k Ω AUX (1,2)160mV, 50k Ω TAPE MONITOR (A,B)160mV, 50k Ω MICROPHONE (A,B)1.6mV, 65k Ω MAIN INPUT500mV, 180k Ω
Output Jacks and Terminals	Speakers (A,B,C) 4 to 16 ohms Stereo Headphones Jacks (A,B) TAPE REcording Jacks (A,B) TAPE REC/P.B. Connector (DIN type) PRE OUTPUT500mV, 13k Ω
Equalization Curve	PHONO.....RIAA
BASS Control	+12.5dB, -14dB (at 50Hz)
TREBLE Control	+9dB, -11dB (at 10kHz)
Filters	LOW.....Cut 6dB (at 50Hz) HIGH.....Cut 12dB (at 10kHz)

Loudness Contour	Switchable to ON-OFF +12dB (at 50Hz), +7dB (at 10kHz), with VOLUME control set at -40dB, VOLUME
Reverberation	Reverberation easily controllable
TONE COLOR Switch	4-position knob for "VIVID", "BASS", "FLAT" and "SOFT"
MICROPHONE Mixing	Stereothrough both "A" and "B" channels Monophonicthrough either "A" or "B" channel

FM TUNER SECTION

Frequency Range	87.5MHz to 108MHz
IHF Sensitivity	1.6 μ V (at 98MHz)
Capture Ratio	1dB (at 98MHz)
Selectivity	40dB (at 98MHz)
Image Rejection	90dB (at 98MHz)
Signal to Noise Ratio	More than 65dB
Antenna Input	300ohms balanced

FM MPX SECTION

Circuit	Time-switching type demodulator FM Mono-Stereo automatic selection
Channel Separation	40dB (at 1kHz)
Harmonic Distortion	0.8% (at 1kHz) 100% Mod.

AM TUNER SECTION

Frequency Range	525kHz to 1,605kHz
IHF Sensitivity	9.5 μ V
Image Rejection	78dB (at 1,000kHz)
Antenna Input	Built-in ferrite loopstick antenna

MISCELLANEOUS

Power Requirements	110, 120, 130, 220 and 240 volts (switchable)
Power Consumption	350 VA (310W) MAX.
Dimensions (Overall)	20-9/16" 522 mm (width) 7-5/8" 194 mm (height) 13-9/16" 344 mm (depth)
Weight	Without Package 34 lb 8 oz 15.7 kg With package 42 lb 3oz 19.2kg

ALIGNMENT INSTRUCTIONS

ALIGNMENT OF FM SECTION

Disconnect OUTPUT terminal of front-end from IN terminal of IF unit

Position of Switch: SELECTOR FM MONO

MUTING OFF

Volume Control Setting: Fully Counterclockwise

STEPS	Input		Level	Dial Setting	Output Equipment Connections	Alignment		
	Equipment Connections	Frequency				Adjust	Remarks	
1	Sweep Generator IN terminal of IF unit	10.7MHz	40dB		Oscilloscope (M) terminal	T ₁ T ₂ T ₃ of IF Unit	Adjust for maximum sensitivity and symmetrical characteristics	
2			80dB					Check symmetry of curve
3	Remove electrolytic capacitor C ₁₂ (of FM IF Unit 4.7μF) in detector circuit							
4	Sweep Generator IN terminal of IF unit	10.7MHz	40dB		Oscilloscope OUT terminal	T ₄ of IF Unit	Adjust the primary core of T ₄ so that slope of straight portion of "S" curve will become the steepest and adjust the secondary core so that the center of "S" curve will coincide with the center of the marker.	
5	Connect OUTPUT terminal of front-end to IN terminal of IF unit							
6	Sweep Generator TP of Front-end	10.7MHz	40dB	Point of no interference as near as 88MHz	Oscilloscope (M) terminal	T ₂ of front-end	Adjust for maximum sensitivity and symmetrical characteristics	
7			80dB					Check symmetry of curve I OF
8			40dB					Adjust similarly to STEP 4.
9	Connect electrolytic capacitor C ₁₂ (4.7μF)							
10	Signal Generator FM Antenna terminal	90MHz	20dB (400Hz 30%)	90MHz	Oscilloscope V T V M OUT terminal	L ₅ of front-end	Adjust for maximum deflection	
11		106MHz		106MHz		CT ₄ of front-end		
12	Repeat STEPS 10 and 11 several times							
13	Signal Generator FM Antenna terminal	90MHz	10dB (400Hz 30%)	90MHz	Oscilloscope V T V M OUT terminal	L ₁ , T ₁ , T ₂ of front-end	Adjust for maximum deflection	
14		106MHz		106MHz		CT ₁ , CT ₂ , CT ₃ of front-end		
15	Repeat STEPS 13 and 14 several times							

ALIGNMENT OF MPX SECTION

Position of Switch: SELECTOR ... FM AUTO
 MUTING ... OFF
 Volume Control Setting: Fully Counterclockwise
 Input Signal: Main (L+R) 40.5KHz Deviation (60%)
 19KHz Pilot 7.5KHz Deviation (10%)

STEPS	Circuit to be adjusted	Input		Connect VTVM	Alignment	
		Connections	Signal		Adjust	Remarks
1	Separation	MPX SG to FM Antenna terminal	Sub (L-R)	AC VTVM REC terminal L or R	L ₁	Adjust for maximum deflection.
2			L or R		VR ₁	Adjust for minimum deflection of the other channel.

ALIGNMENT OF AM SECTION

*VTVM and oscilloscope should be connected in parallel at the output.

Position of Switch: SELECTOR.....MW

Volume Control Setting: Fully Counterclockwise

STEPS	Input			Dial Setting	Output Equipment Connections	Alignment	
	Equipment Connections	Frequency	Level			Adjust	Remarks
1	Sweep Generator 12	455kHz	60dB	Point of no interference as near as 1605kHz	VTVM Oscilloscope 8	T3 T4 T5	Adjust for maximum sensitivity and symmetrical characteristics.
2	Signal Generator Antenna Terminal through dummy	600kHz	30dB	600kHz	VTVM Oscilloscope 8	T2	Adjust for maximum deflection
3		1400kHz		1400kHz		CT3	
4	Repeat steps 2 and 3 several times.						
5	Signal Generator Antenna Terminal through dummy	600kHz	30dB	600kHz	VTVM Oscilloscope 8	T1, Ferrite Antenna (Adjusting core)	Adjust for maximum deflection.
6		1400kHz		1400kHz		CT1 CT2	
7	Repeat steps 5 and 6 several times.						

PARTS LAYOUT

TOP VIEW

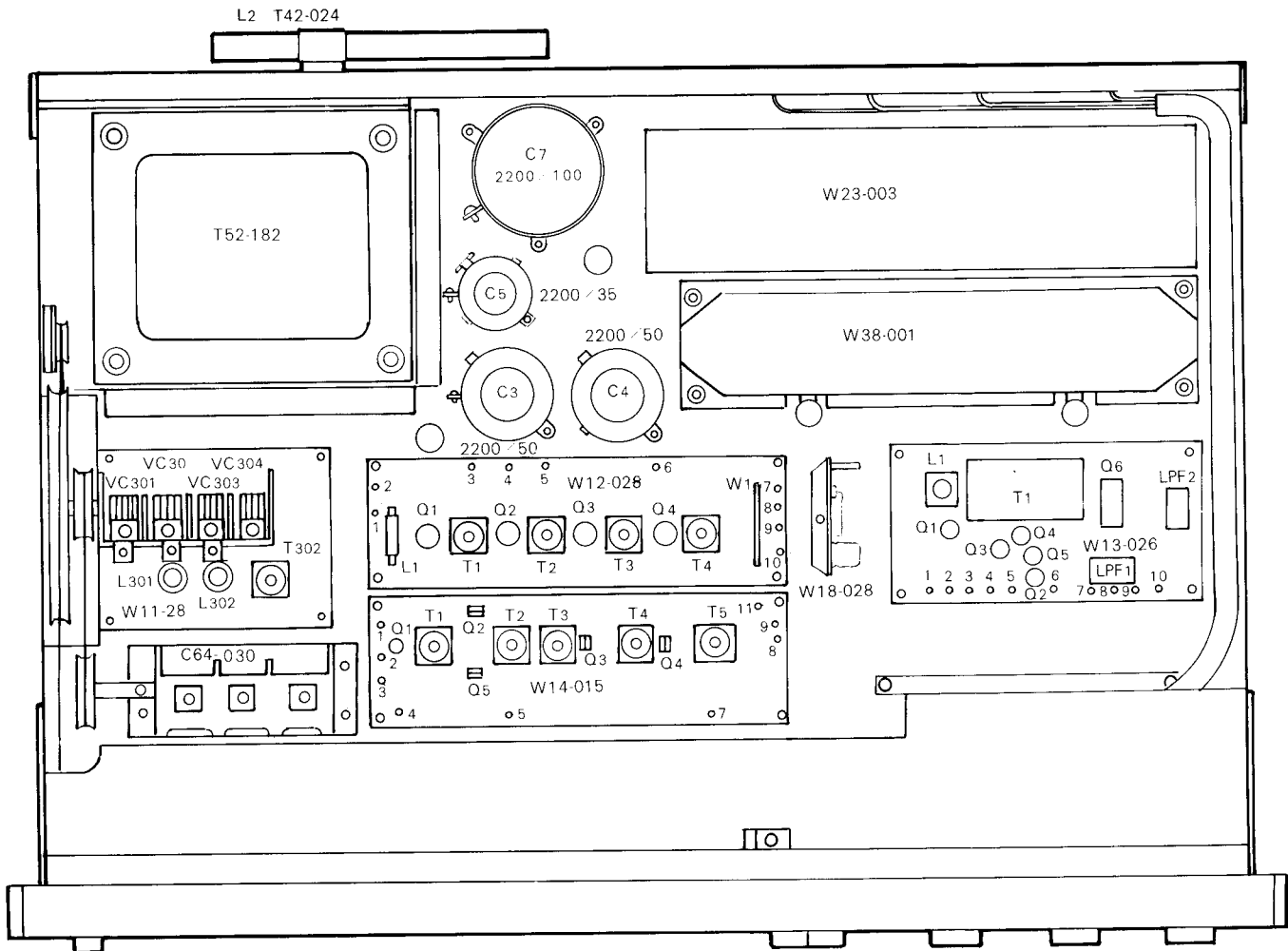

DIAL CORD STRINGING

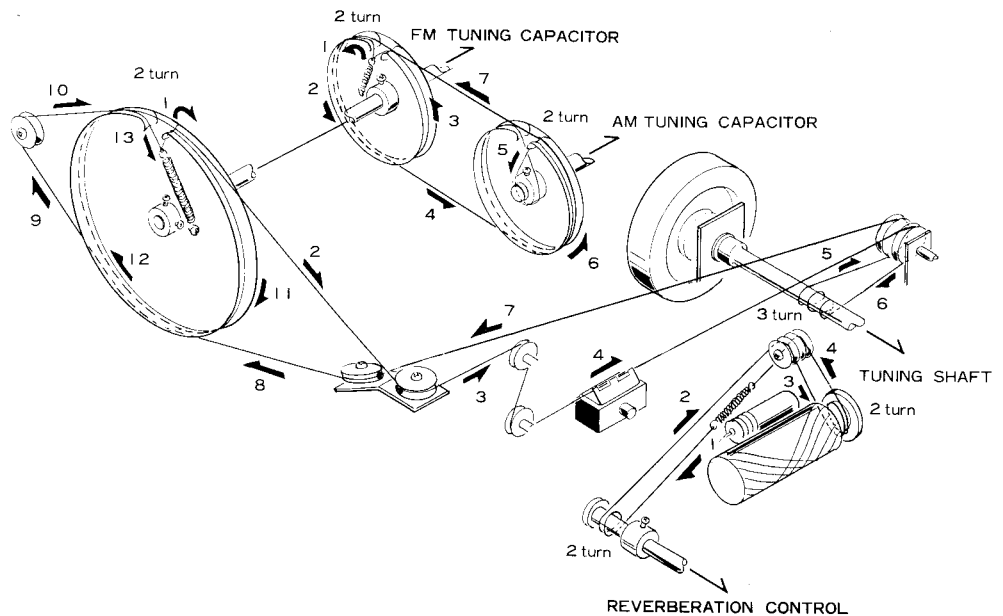

BOTTOM VIEW

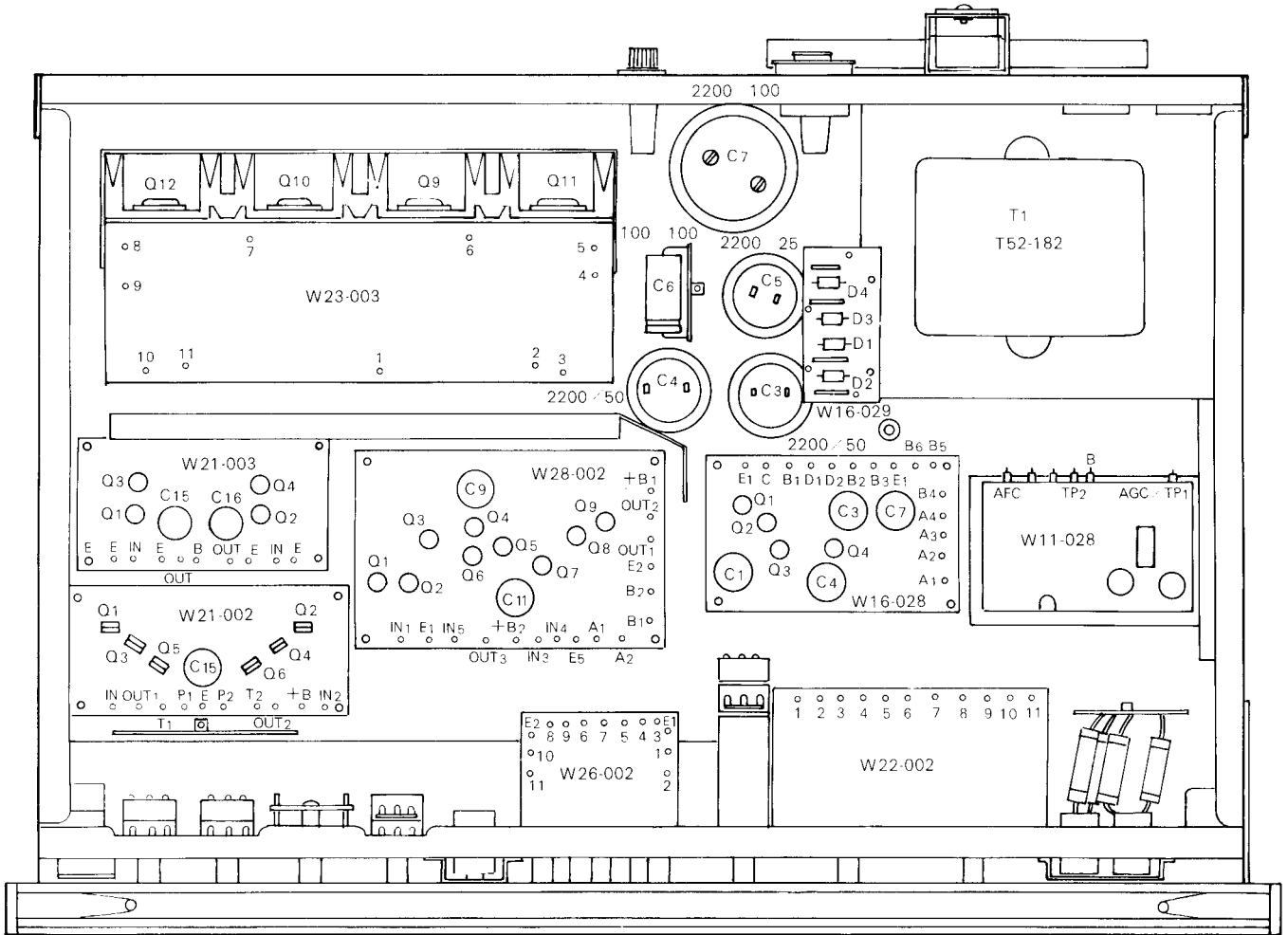

PRINTED CIRCUIT BOARDS

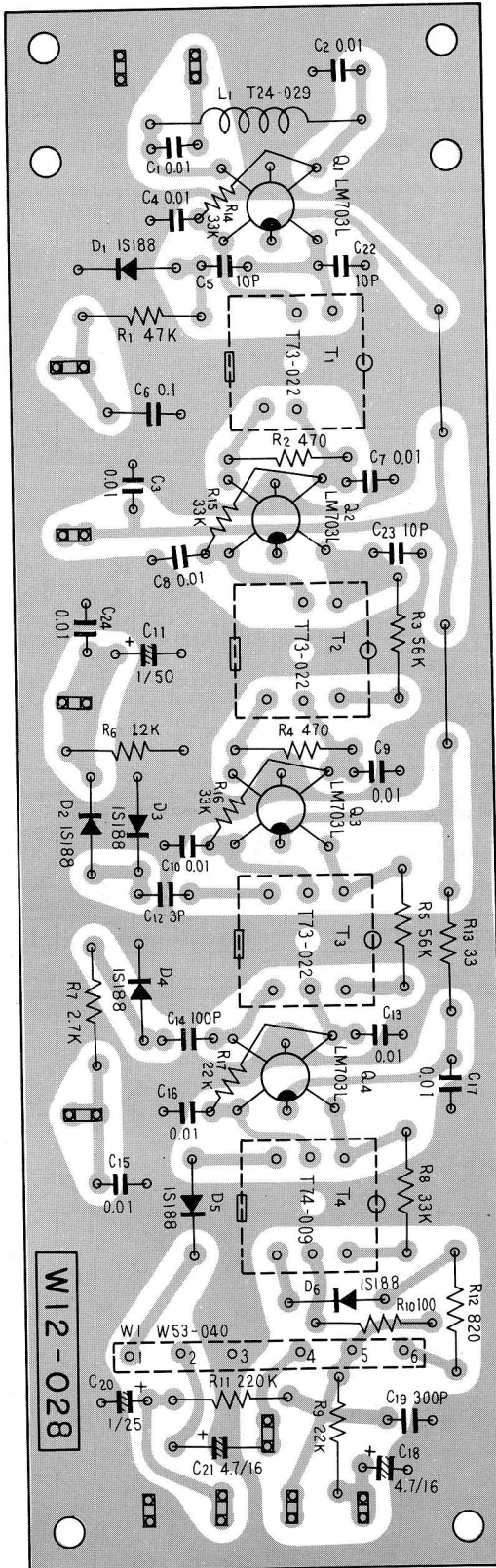
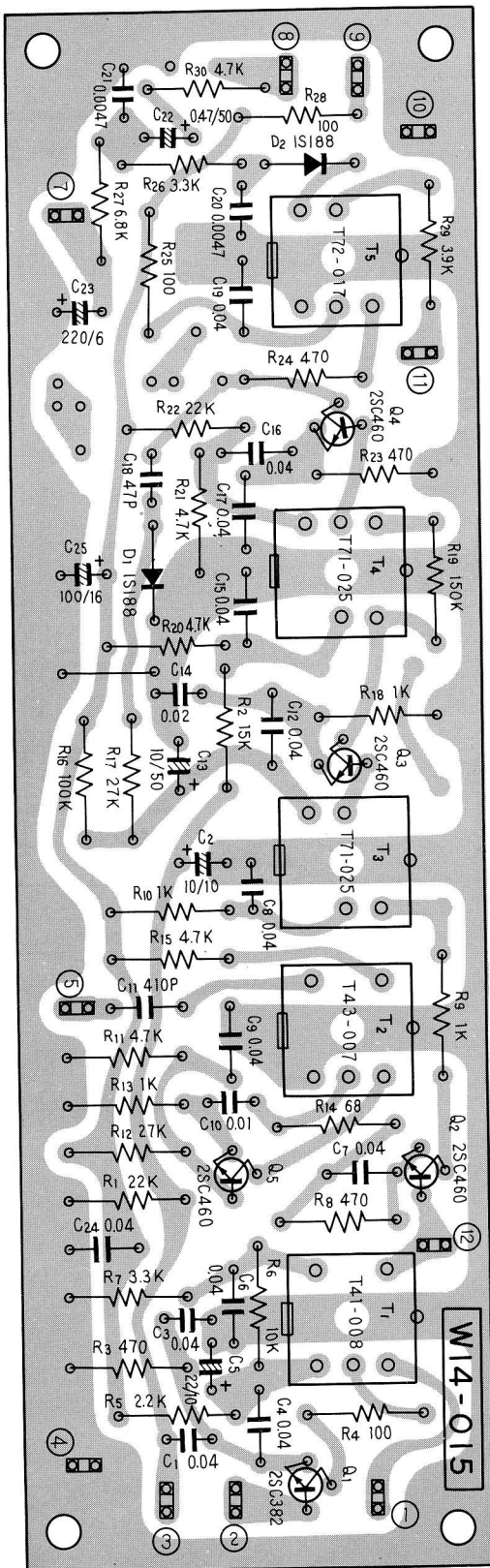

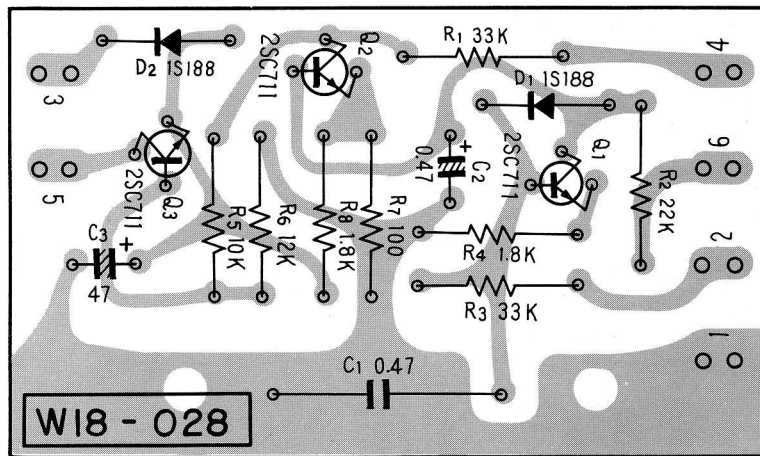
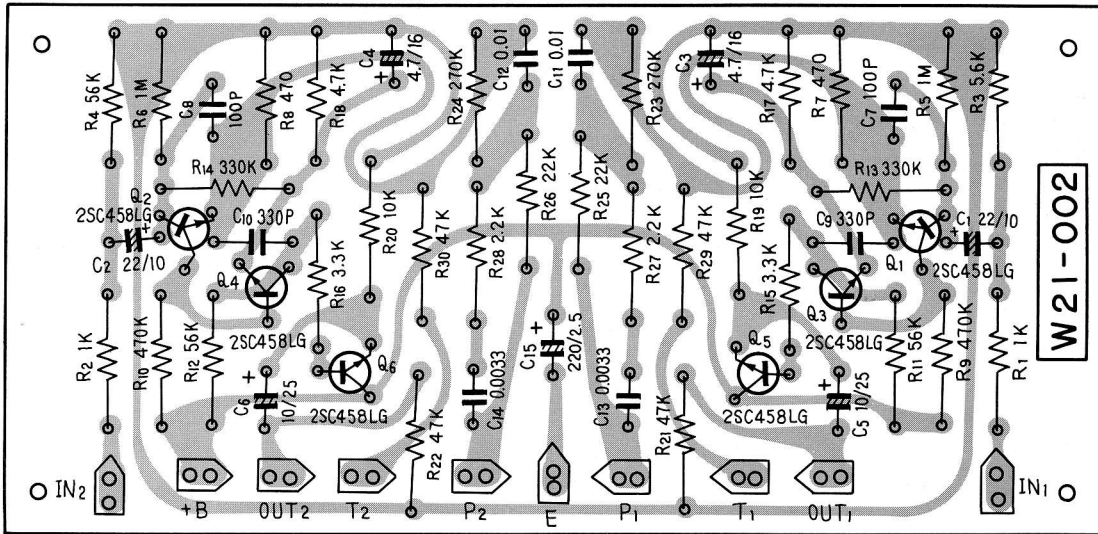
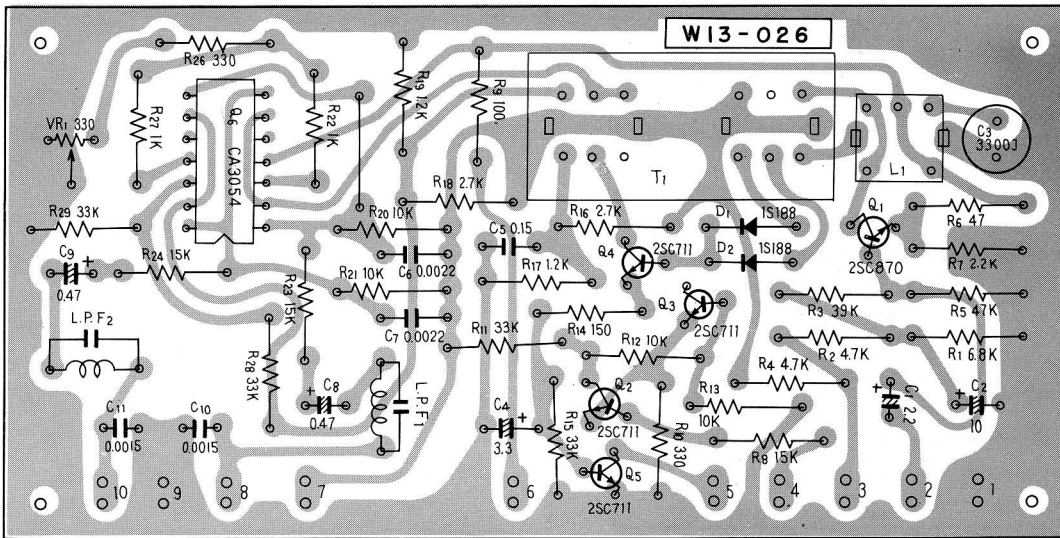

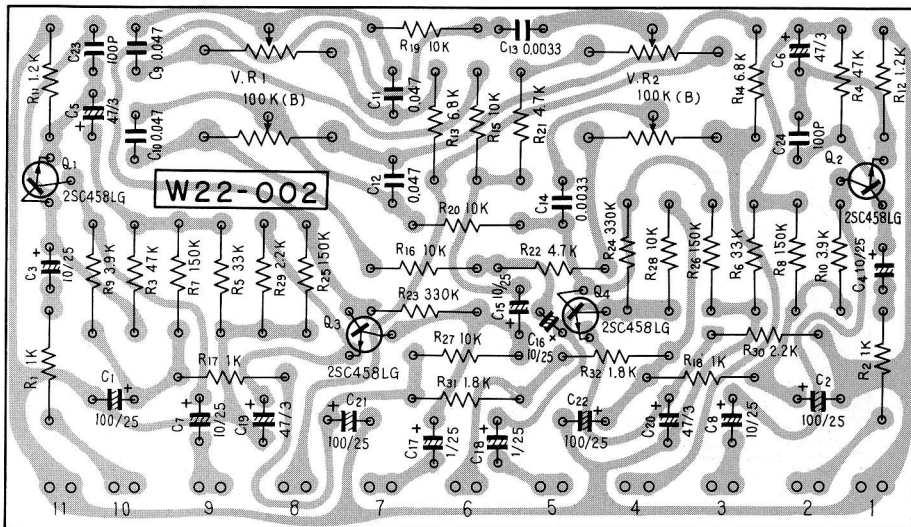
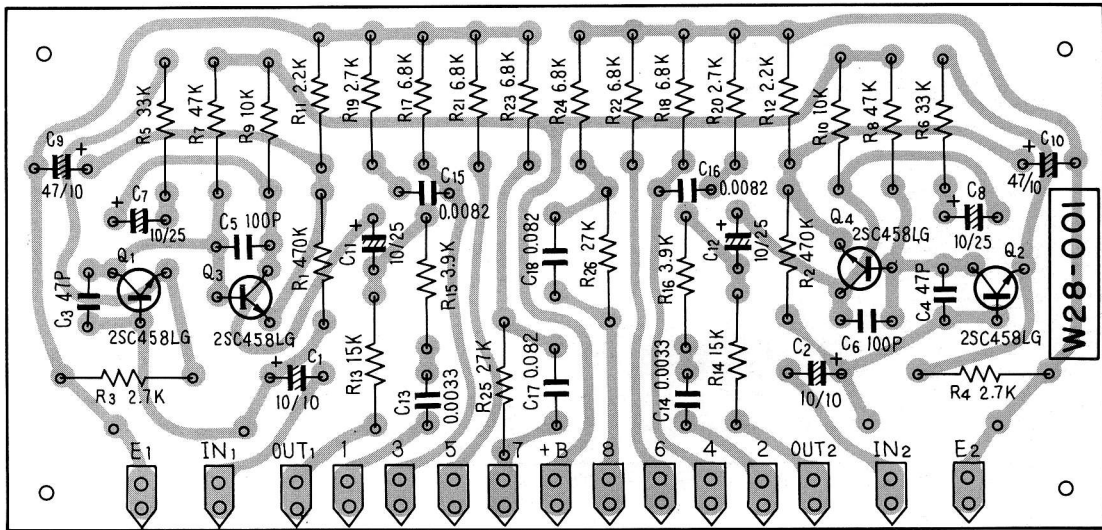
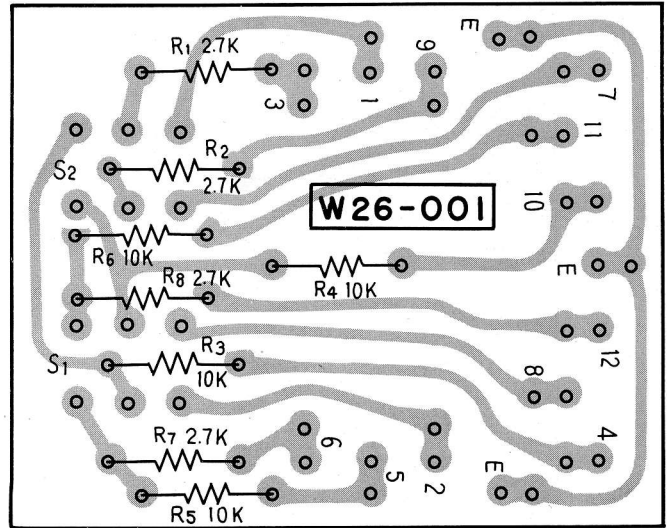
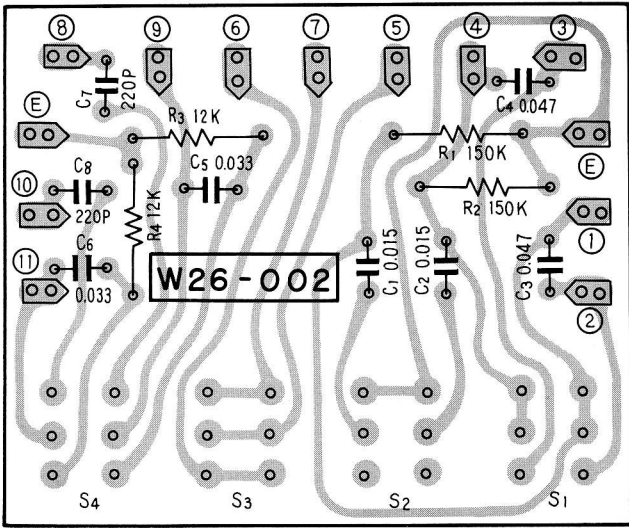

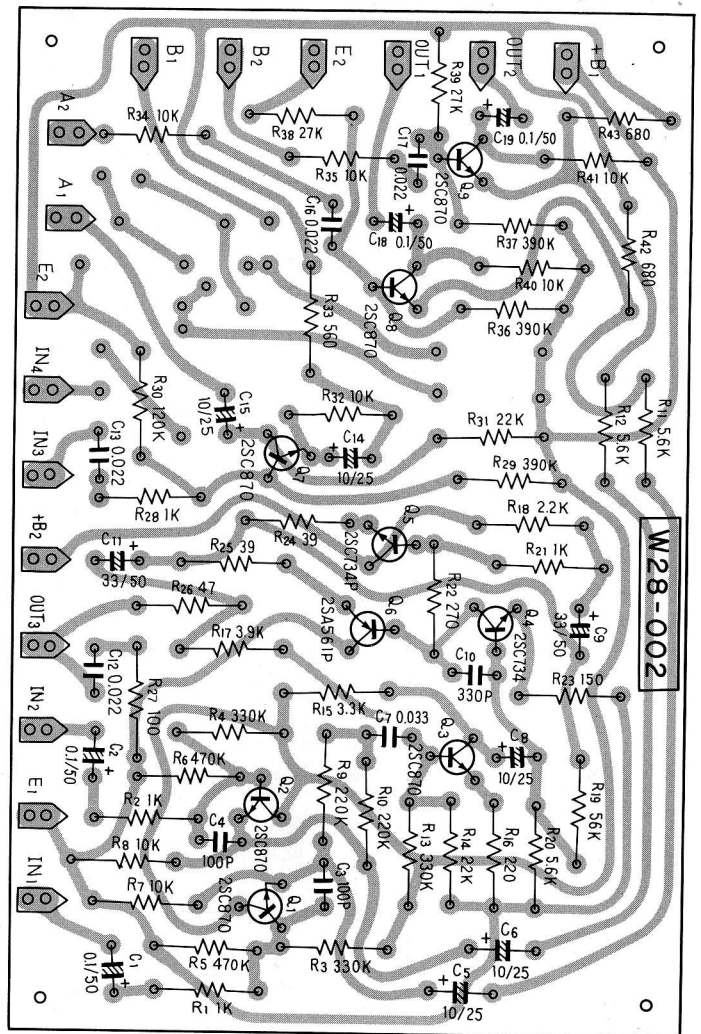
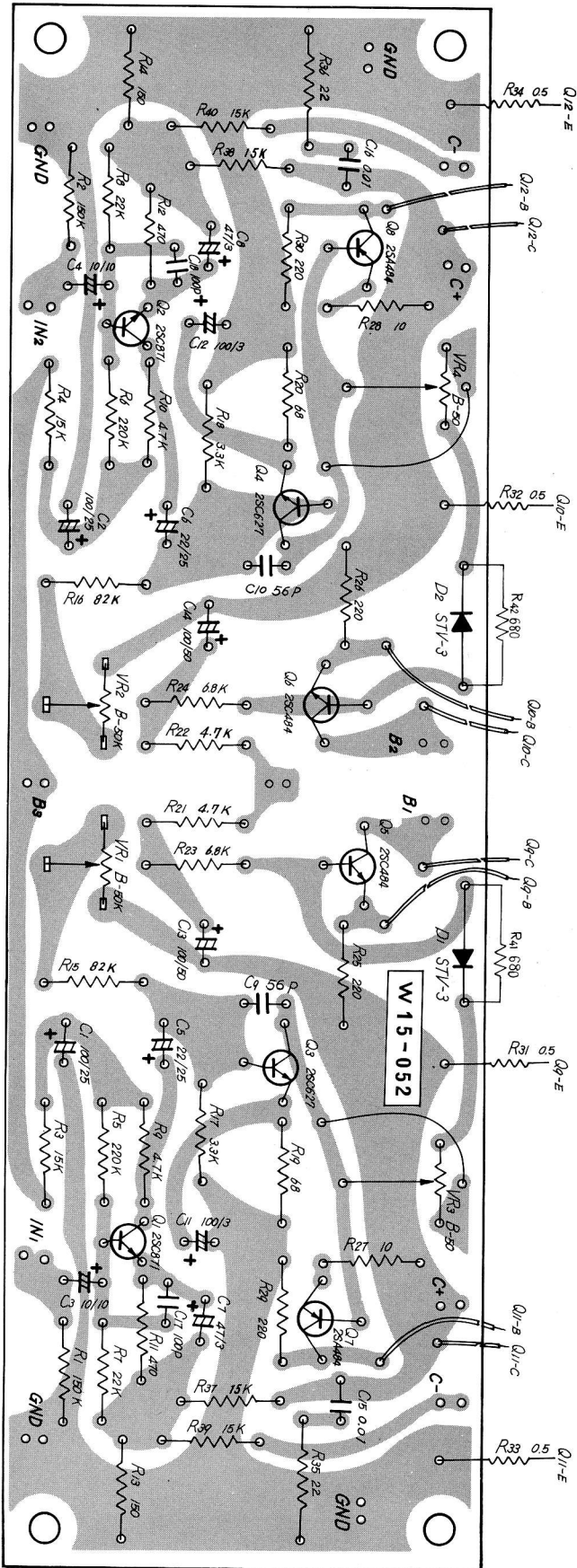

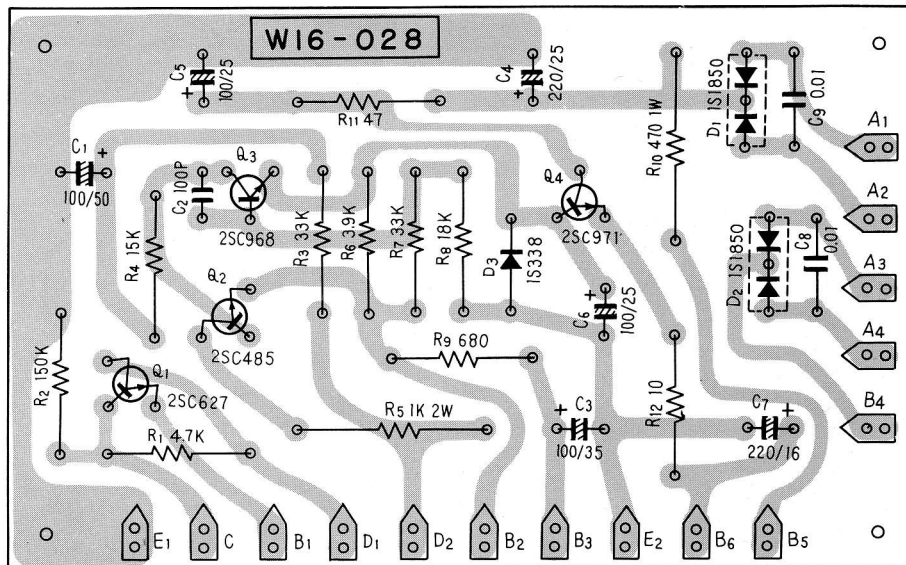
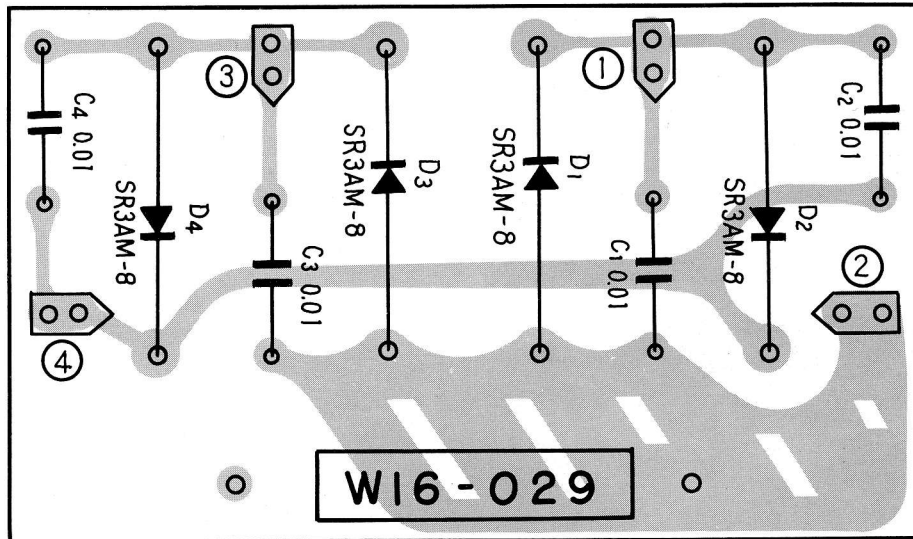
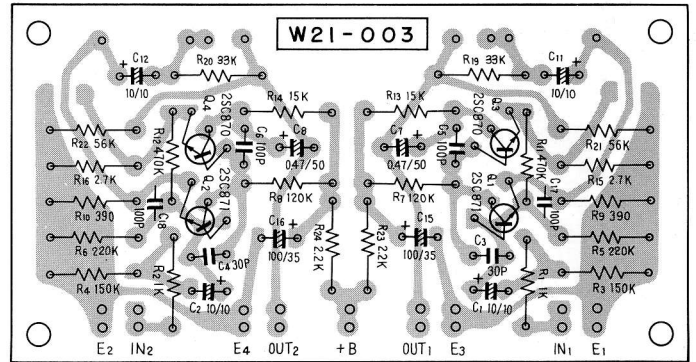
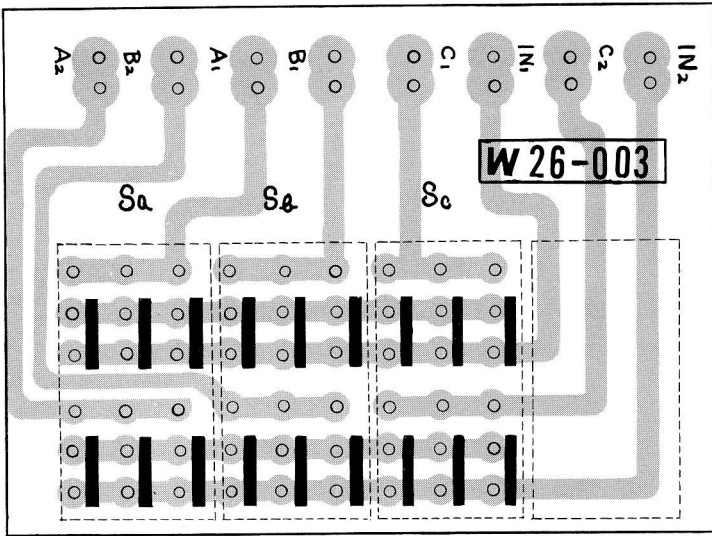

PARTS LIST

CAPACITORS

IN μF , 10% TOLERANCE UNLESS OTHERWISE NOTED P: μF

Symbol	Description			Part No.
C1	Ceramic	0.01	50V	CKDYZ 103K 50
C2	Ceramic	0.01	50V	CKDYZ 103K 50
C3	Electrolytic	2200	50V	C52-045-A
C4	Electrolytic	2200	50V	C52-045-A
C5	Electrolytic	2200	35V	C52-075-O
C6	Electrolytic	100	100V	CETG 100MF 100V
C7	Electrolytic	2200	100V	C52-076
C8	Ceramic	0.01	D.C 1.4KV	C43-003-O
C9	Ceramic	0.01	D.C 1.4KV	C43-003-O
C10	Ceramic	0.01	D.C 1.4KV	C43-003-O
C11	Ceramic	3p	50V	CCDSL 030C 50
C12	Mylar	2200p	50V	CQMA 222K 50
C13	Mylar	2200p	50V	CQMA 222K 50
C14	Electrolytic	220	35V	CETG 220MF 35V

RESISTORS

IN Ω , $\frac{1}{4}\text{W}$, 10% TOLERANCE UNLESS OTHERWISE NOTED
k:k Ω M:M Ω

Symbol	Description			Part No.
R1	Carbon film	150k		RF $\frac{1}{4}$ PS 150K-K NL
R2	Carbon film	150k		RF $\frac{1}{4}$ PS 150K-K NL
R3	Carbon film	2.2k		RF $\frac{1}{4}$ PS 2R2K-K
R4	Carbon film	56k		RF $\frac{1}{4}$ PS 56K-K
R5	Carbon film	56k		RF $\frac{1}{4}$ PS 56K-K
R6	Carbon film	47k		RF $\frac{1}{4}$ PS 47K-K NL
R7	Carbon film	47k		RF $\frac{1}{4}$ PS 47K-K NL
R8	Carbon film	56k		RF $\frac{1}{4}$ PS 56K-K NL
R9	Carbon film	56k		RF $\frac{1}{4}$ PS 56K-K NL
R10	Carbon film	56k		RF $\frac{1}{4}$ PS 56K-K NL
R11	Carbon film	56k		RF $\frac{1}{4}$ PS 56K-K NL
R12	Carbon film	4.7k		RF $\frac{1}{4}$ PS 4R7K-K NL
R13	Carbon film	4.7k		RF $\frac{1}{4}$ PS 4R7K-K NL
R14	Carbon film	3.3k		RF $\frac{1}{4}$ PS 3R3K-K NL
R15	Carbon film	82k		RF $\frac{1}{4}$ PS 82K-K
R16	Carbon film	82k		RF $\frac{1}{4}$ PS 82K-K
R17	Carbon film	1k		RF $\frac{1}{4}$ PS 1K-K
R18	Wire wound	150	3W	RO3P 150-K
R19	Wire wound	150	3W	RO3P 150-K
R20	Wire wound	150	3W	RO3P 150-K
R21	Wire wound	150	3W	RO3P 150-K
R22	Carbon film	56k		RF $\frac{1}{4}$ PS 56K-K NL
R23	Carbon film	2.7k		RF $\frac{1}{4}$ PS 2R7K-K NL
R24	Carbon film	8.2k		RF $\frac{1}{4}$ PS 8R2K-K
R25	Carbon film	56k		RF $\frac{1}{4}$ PS 56K-K
R26	Carbon film	33k		RF $\frac{1}{4}$ PS 33K-K NL
R27	Carbon film	33k		RF $\frac{1}{4}$ PS 33K-K NL
R28	Carbon film	4.7k		RF $\frac{1}{4}$ PS 4R7K-K NL
R29	Carbon film	4.7k		RF $\frac{1}{4}$ PS 4R7K-K NL
R30	Carbon film	2.2k		RF $\frac{1}{4}$ PS 2R2K-K

COILS AND TRANSFORMER

Symbol	Description	Part No.
T1	Power Transformer	T52-182-O
L1	Choke Coil	T24-030-O
L2	AM-Ferrite Loopstick Antenna	T42-024-A
L3	Choke Coil	T24-025-B

SWITCHES

Symbol	Description	Part No.
S1	Input Selector	S13-038-A
S2	Mode Selector	S14-035-O
S3	Selector Switch	S15-035-A
S7	Slide Switch	S11-022-A
S8	Power Switch	S11-030-A
S9	Line Voltage Selector	S11-018-O

POTENTIOMETERS

Symbol	Description	Part No.
VR1	Volume Control (250k-A2)	C85-010-O
VR2	Volume Control with switch (50k-A2)	C85-056-O
VR3	Volume Control with switch (50k-A2)	C85-056-O
VR4	Volume Control (250k-A2)	C88-010-O
VR5	Volume Control with switch (50k-HB)	C85-055-O

COMPOUND PART

Symbol	Description	Part No.
	TAPE REC Terminal	W52-004-O

OTHER

Symbol	Description	Part No.
	AM Variable Capacitor	C64-030-O

MISCELLANEOUS

Symbol	Description	Part No.
	Front Panel Ass'y	M21-354-A
	Front Panel	M21-355-A
	Side Panel(R)	M21-356-O
	Side Panel(L)	M21-357-O
	Front Cover	M21-358-O
	Escutcheon	A61-217-A
	Dial Board	A62-055-B
	Shaft	B28-002-O
	Packing	E31-145-A
	Spring for Front Cover	B31-016-O
	Dial Pulley (Small)	M42-054-O
	Dial Pulley for Reverberation Control	M42-053-A
	Dial Pulley for FM Tuning Capacitor	M42-027-D
	Dial Pulley for AM and FM Tuning Capacitor	M42-021-C
	Dial Pulley	M42-009-B
	Foot	M61-017-O
	AM Ferrite Loopstick Antenna Ass'y	W72-002-B
	Pilot Lamp for Dial Board	E22-017-O
	Pilot lamp for Program Indicator	E22-018-A
	Pilot Lamp for Stereo Indicator	E22-029-O
	Pilot Lamp Ass'y for Dial Pointer	E22-031-O
	Pilot Lamp for Signal Meter (8V 150mA)	E22-002-O
	Pilot Lamp for Reverb (8V 250mA)	E22-026-O
	Pilot Lamp Ass'y for Tone Color	E22-030-B
	Fuse 1.5A	E21-012-O
	Fuse 3A	E21-006-O
	Dial Board for Tuning	A33-110-A
	Pulley for Reverberation	A59-051-O
	Lens for Pilot Lamp	A62-054-O
	Paper for Dial Pulley in Reverberation	A55-008-A

Meter Escutcheon	A61-216-O
Meter for Signal	A91-009-D
Meter for FM Tuning	A91-008-D
Lens for Program Indicator Lamp (RED)	A62-039-B
Lens for Program Indicator Lamp (BLUE)	A62-040-B
Lens for Program Indicator Lamp (GREEN)	A62-041-B
Lens for Program Indicator Lamp (WHITE)	A62-042-B
Lens for Program Indicator Lamp (PINK)	A62-043-B
Knob for MODE	A12-203-B
Knob for BASS, TREBLE, REVERB, BALANCE, MIC A, and MIC B	A12-195-B
Knob for SELECTOR, TONE COLOR	A12-197-B
Knob for TUNING	A12-196-A
Knob for MASTER VOLUME	A13-020-B
Knob for SOURCE VOLUME	A13-021-A
Knob for POWER SWITCH	A19-038-O
Knob for TAPE MONITOR A, TAPE MONITOR B (DEMI SWITCH)	A19-078-O
Knob for LOW FILTER, HIGH FILTER, FM MUTING LOUDNESS	A19-077-O
6p Input Terminal	K22-013-C
4P Input Terminal	K21-010-D
1P Input Terminal	K21-005-C
4P Antenna Terminal	K11-018-O
Spare A, C Outlet	K82-012-O
Socket for Speaker	K73-028-O
Jack for Headphone	K72-026-O
Jack for Microphone	K72-024-O
Socket for Pilot Lamp	K41-002-B
Fuse holder (1p)	K91-005-A
5P Connector (DIN type)	K93-003-B
Fuse holder for Protection Circuit	K96-006-C
Short Pin Plug	K71-028-O
FM Front-end Unit	W11-028-D
FM IF Unit	W12-028-O
AM Tuner Unit	W14-015-A
FM MPX Unit	W13-026-O
Muting Unit	W18-028-A
Head Amp Unit	W21-002-O
Control Amp Unit	W22-002-O
Main Amp Unit	W15-052-F
MIC Amp Unit	W21-003-A
Reverb Amp Unit	W28-002-O
Tone Color Unit	W28-001-O
Demi Switch Unit	W26-001-A
Demi Switch Unit	W26-002-O
Push Switch Unit	W26-003-O
Power Supply Unit	W16-028-O
Power Supply Unit	W16-029-O
Reverberation Unit	W38-001-O

FM FRONT-END UNIT (W11-028) CAPACITORS

Symbol	Description	Part No.
C1	Ceramic 1000p 25V	CKDYZ 102P 25
C3	Ceramic 6p 50V	CCDSL 060C 50
C4	Ceramic 1000p 500V	C47-005-A
C5	Ceramic 1000p 500V	C47-005-A
C6	Ceramic 10p 50V	CCDSL 100K 50
C7	Ceramic 10p 50V	CCDSL 100K 50
C8	Ceramic 10p 50V	CCDSL 100K 50
C9	Ceramic 5p 50V	CCDSL 050D 50
C10	Ceramic 100p 500V	C47-004-O

C11	Ceramic	1p	500V	C43-002-O
C12	Ceramic	1000p	500V	C47-005-A
C13	Ceramic	0.01	25V	CKDYZ 103P 25
C14	Ceramic	1000p	500V	C47-005-A
C15	Ceramic	5p	50V	CCDUJ 050D 50
C16	Ceramic	5p	50V	CCDSH 050D 50
C17	Ceramic	7p	50V	CCDTJ 070D 50
C18	Ceramic	1000p	500V	C47-005-A
C19	Ceramic	1000p	500V	C47-005-A
C20	Ceramic	1000p	500V	C47-005-A

RESISTORS

Symbol	Description	Part No.
R1	Carbon film 100k 1/8W	RF1/8PS 100K-K
R2	Carbon film 1M 1/8W	RF1/8PS 1M-K
R3	Carbon film 220 1/8W	RF1/8PS 220K
R4	Carbon film 3.9k 1/8W	RF1/8PS 3R9K-K
R5	Carbon film 22k 1/8W	RF1/8PS 22K-K
R6	Carbon film 1k 1/8W	RF1/8PS 1K-K
R7	Carbon film 220 1/8W	RF1/8PS 220 K
R8	Carbon film 8.2k 1/8W	RF1/8PS 8R2K-K
R9	Carbon film 2.2k 1/8W	RF1/8PS 2R2K-K
R10	Carbon film 1.5k 1/8W	RF1/8PS 1R5K-K
R11	Carbon film 22k 1/8W	RF1/8PS 22K K
R12	Carbon film 22k 1/8W	RF1/8PS 22K K
R13	Carbon film 3.3k 1/8W	RF1/8PS 3R3K-K

COILS

Symbol	Description	Part No.
L1	RF Coil	T21-013-B
L2	RF Coil	T23-026-D
L5	OSC Coil	T23-032-B

SEMICONDUCTORS

Symbol	Description	Part No.
D1	1S85 Diode	
Q1	3SK22-Y Transistor	
Q2	2SC461-B Transistor	
Q3	2SC461-A Transistor	

FM IF UNIT (W12-028) CAPACITORS

Symbol	Description	Part No.
C1	Ceramic 0.01 25V	CKDYZ 103P 25
C2	Ceramic 0.01 25V	CKDYZ 103P 25
C3	Ceramic 0.01 25V	CKDYZ 103P 25
C4	Ceramic 0.01 25V	CKDYZ 103P 25
C5	Ceramic 10p 50V	CCDSL 100K 50
C6	Mylar 0.1 50V	CQMA 104M 50
C7	Ceramic 0.01 25V	CKDYZ 103P 25
C8	Ceramic 0.01 25V	CKDYZ 103P 25
C9	Ceramic 0.01 25V	CKDYZ 103P 25
C10	Ceramic 0.01 25V	CKDYZ 103P 25
C11	Electrolytic 1 50V	CEMX 1MF 50V
C12	Ceramic 3p 50V	CCDSL 030C 50
C13	Ceramic 0.01 25V	CKDYZ 103P 25
C14	Ceramic 100p 50V	CCDSL 101K 50
C15	Ceramic 0.01 25V	CKDYZ 103P 25
C16	Ceramic 0.01 25V	CKDYZ 103P 25
C17	Ceramic 0.01 25V	CKDYZ 103P 25

C18	Electrolytic	4.7	16V	CEMX 4R7MF 16V
C19	Ceramic	300p	50V	CCDSL 301K 50
C20	Electrolytic	1	25V	CEMX 1MF 25V
C21	Electrolytic	4.7	16V	CEMX 4R7MF 16V
C22	Ceramic	10p	50V	CCDSL 100K 50
C23	Ceramic	10p	50V	CCDSL 100K 50
C24	Ceramic	0.01	25V	CKDYZ 103P 25

RESISTORS

Symbol	Description	Part No.
R1	Carbon film 47k	RF $\frac{1}{4}$ PS 47K-K
R2	Carbon film 470	RF $\frac{1}{4}$ PS 470-K
R3	Carbon film 56k	RF $\frac{1}{4}$ PS 56K-K
R4	Carbon film 470	RF $\frac{1}{4}$ PS 470-K
R5	Carbon film 56k	RF $\frac{1}{4}$ PS 56K-K
R6	Carbon film 12k	RF $\frac{1}{4}$ PS 12K-K
R7	Carbon film 2.7k	RF $\frac{1}{4}$ PS 2R7K-K
R8	Carbon film 33k	RF $\frac{1}{4}$ PS 33K-K
R9	Carbon film 22k	RF $\frac{1}{4}$ PS 22K-K
R10	Carbon film 100	RF $\frac{1}{4}$ PS 100-K
R11	Carbon film 220k	RF $\frac{1}{4}$ PS 220K-K
R12	Carbon film 820	RF $\frac{1}{4}$ PS 820-K
R13	Carbon film 150	RF $\frac{1}{4}$ PS 150-K

COILS AND TRANSFORMER

Symbol	Description	Part No.
T1	FM IFT	T73-022-O
T2	FM IFT	T73-022-O
T3	FM IFT	T73-022-O
T4	FM DET IFT	T74-009-O
L1	RF Choke Coil	T24-029-A

SEMICONDUCTORS

Symbol	Description	Part No.
D1	1S188 or FM-1 Diode	
D2	1S188 or FM-1 Diode	
D3	1S188 or FM-1 Diode	
D4	1S188 or FM-1 Diode	
D5	1S188 or FM-1 Diode	
D6	1S188 or FM-1 Diode	
Q1	LM703L-BL IC	
Q2	LM703L-BL IC	
Q3	LM703L-BL IC	
Q4	LM703L-BL IC	

MUTING UNIT (W18-028) CAPACITORS

Symbol	Description	Part No.
C1	Mylar 0.47	50V CQMA 474K 50
C2	Electrolytic 0.47	50V CEMX R47MF 50V
C3	Electrolytic 47	25V CEMX 47MF 25V

RESISTORS

Symbol	Description	Part No.
R1	Carbon film 33k	RF $\frac{1}{4}$ PS 33K-K
R2	Carbon film 22k	RF $\frac{1}{4}$ PS 22K-K
R3	Carbon film 33k	RF $\frac{1}{4}$ PS 33K-K
R4	Carbon film 1.8k	RF $\frac{1}{4}$ PS 1R8K-K
R5	Carbon film 10k	RF $\frac{1}{4}$ PS 10K-K
R6	Carbon film 12k	RF $\frac{1}{4}$ PS 12K-K
R7	Carbon film 100	RF $\frac{1}{4}$ PS 100-K
R8	Carbon film 1.8k	RF $\frac{1}{4}$ PS 1R8K-K

SEMICONDUCTORS

Symbol	Description	Part No.
D1	1S188 or FM-1 Diode	
D2	1S188 or FM-1 Diode	
Q1	2SC711 Transistor	
Q2	2SC711 Transistor	
Q3	2SC711 Transistor	

MIC AMP UNIT (W21-003) CAPACITORS

Symbol	Description	Part No.
C1	Electrolytic 10	10V CEMX 10MF 10V
C2	Electrolytic 10	10V CEMX 10MF 10V
C3	Ceramic 30p	50V CCDSL 300K 50V
C4	Ceramic 30p	50V CCDSL 300K 50
C5	Ceramic 100p	50V CCDSL 101K 50
C6	Ceramic 100p	50V CCDSL 101K 50
C7	Electrolytic 0.47	50V CEMX B47MF 50V
C8	Electrolytic 0.47	50V CEMX R47MF 50V
C11	Electrolytic 10	10V CEMX 10MF 10V
C12	Electrolytic 10	10V CEMX 10MF 10V
C15	Electrolytic 100	35V CEMX 100MF 35V
C16	Electrolytic 100	35V CEMX 100MF 35V

RESISTORS

Symbol	Description	Part No.
R1	Carbon film 1k	RF $\frac{1}{4}$ PS 1K-K
R2	Carbon film 1k	RF $\frac{1}{4}$ PS 1K-K
R3	Carbon film 150k	RF $\frac{1}{4}$ PS 150K-K
R4	Carbon film 150k	RF $\frac{1}{4}$ PS 150K-K
R5	Carbon film 220k	RF $\frac{1}{4}$ PS 220K-K
R6	Carbon film 220k	RF $\frac{1}{4}$ PS 220K-K
R7	Carbon film 120k	RF $\frac{1}{4}$ PS 120K-K
R8	Carbon film 120k	RF $\frac{1}{4}$ PS 120K-K

R 9	Carbon film	390		RF $\frac{1}{4}$ PS 390-K
R10	Carbon film	390		RF $\frac{1}{4}$ PS 390-K
R11	Carbon film	470k		RF $\frac{1}{4}$ PS 470K-K
R12	Carbon film	470k		RF $\frac{1}{4}$ PS 470K-K
R13	Carbon film	15k		RF $\frac{1}{4}$ PS 15K-K
R14	Carbon film	15k		RF $\frac{1}{4}$ PS 15K-K
R15	Carbon film	2.7k		RF $\frac{1}{4}$ PS 2R7K-K
R16	Carbon film	2.7k		RF $\frac{1}{4}$ PS 2R7K-K
R19	Carbon film	33k		RF $\frac{1}{4}$ PS 33K-K
R10	Carbon film	33k		RF $\frac{1}{4}$ PS 33K-K
R11	Carbon film	56k		RF $\frac{1}{4}$ PS 56K-K
R22	Carbon film	56k		RF $\frac{1}{4}$ PS 56K-K
R23	Carbon film	2.2k		RF $\frac{1}{4}$ PS 2R2K-K
R24	Carbon film	2.2k		RF $\frac{1}{4}$ PS 2R2K-K

TRANSISTORS

Symbol	Description	Part No.
Q1	2SC871-GR	
Q2	2SC871-GR	
Q3	2SC870	
Q4	2SC870	

MPX UNIT (W13-026) CAPACITORS

Symbol	Description	Part No.
C1	Electrolytic 2.2 50V	CEMX 2R2MF 50V
C2	Electrolytic 10 10V	CEMX 10MF 10V
C3	Styrol 3300p	C15-011
C4	Electrolytic 3.3 25V	CEMX 3R3MF 25V
C5	Mylar 0.15 50V	CQMA 154K 50
C6	Mylar 2200p 50V	CQMA 222K 50
C7	Mylar 2200p 50V	CQMA 222K 50
C8	Electrolytic 0.47 50V	CEMX R47MF 50V
C9	Electrolytic 0.47 50V	CEMX R47MF 50V
C10	Mylar 1500p 50V	CQMA 152K 50
C11	Mylar 1500p 50V	CQMA 152K 50
C12	Ceramic 300p 50V	CCDSL 301K 50

RESISTORS

Symbol	Description	Part No.
R1	Carbon film 6.8k	RF $\frac{1}{4}$ PS 6R8K-K
R2	Carbon film 4.7k	RF $\frac{1}{4}$ PS 4R7K-K
R3	Carbon film 39k	RF $\frac{1}{4}$ PS 39K-K
R4	Carbon film 4.7k	RF $\frac{1}{4}$ PS 4R7K-K
R5	Carbon film 47k	RF $\frac{1}{4}$ PS 47K-K
R6	Carbon film 47	RF $\frac{1}{4}$ PS 47-K
R7	Carbon film 2.2k	RF $\frac{1}{4}$ PS 2R2K-K
R8	Carbon film 15k	RF $\frac{1}{4}$ PS 15K-K
R9	Carbon film 100	RF $\frac{1}{4}$ PS 100-K
R10	Carbon film 330	RF $\frac{1}{4}$ PS 330-K
R11	Carbon film 33k	RF $\frac{1}{4}$ PS 33K-K
R12	Carbon film 10k	RF $\frac{1}{4}$ PS 10K-K
R13	Carbon film 10k	RF $\frac{1}{4}$ PS 10K-K
R14	Carbon film 150	RF $\frac{1}{4}$ PS 150-K
R15	Carbon film 33k	RF $\frac{1}{4}$ PS 33K-K
R16	Carbon film 2.7k	RF $\frac{1}{4}$ PS 2R7K-K
R17	Carbon film 1.2k	RF $\frac{1}{4}$ PS 1R2K-K
R18	Carbon film 2.7k	RF $\frac{1}{4}$ PS 2R7K-K
R19	Carbon film 1.2k	RF $\frac{1}{4}$ PS 1R2K-K
R20	Carbon film 10k	RF $\frac{1}{4}$ PS 10K-K

R21	Carbon film	10k		RF $\frac{1}{4}$ PS 10K-K
R22	Carbon film	1k		RF $\frac{1}{4}$ PS 1K-K
R23	Carbon film	15k		RF $\frac{1}{4}$ PS 15K-K
R24	Carbon film	15k		RF $\frac{1}{4}$ PS 15K-K
R26	Carbon film	330		RF $\frac{1}{4}$ PS 330-K
R27	Carbon film	1k		RF $\frac{1}{4}$ PS 1K-K
R28	Carbon film	33k		RF $\frac{1}{4}$ PS 33K-K
R29	Carbon film	33k		RF $\frac{1}{4}$ PS 33K-K

COILS AND TRANSFORMER

Symbol	Description	Part No.
L1	19kHz Coil	T75-023-O
T1	MPX Transformer	T75-026-O
LPF1	38kHz Filter	T75-015-A
LPF2	38kHz Filter	T75-015 A

DIODES AND TRANSISTORS

Symbol	Description	Part No.
D1	1S188 or FM-1 Diode	
D2	1S188 or FM-1 Diode	
Q1	2SC870-F Transistor	
Q2	2SC711-F Transistor	
Q3	2SC711-F Transistor	
Q4	2SC711-F Transistor	
Q5	2SC711-F Transistor	
Q6	CA3054 IC	

AM UNIT (W14-015) CAPACITORS

Symbol	Description	Part No.
C1	Ceramic 0.04 25V	CKDYZ 403P 25
C2	Electrolytic 10 10V	CEMX 10MF 10V
C3	Ceramic 0.04 25V	CKDYZ 403P 25
C4	Ceramic 0.04 25V	CKDYZ 403P 25
C5	Electrolytic 22 10V	CEMX 22MF 10V
C6	Ceramic 0.04 25V	CKDYZ 403P 25
C7	Ceramic 0.04 25V	CKDYZ 403P 25
C8	Ceramic 0.04 25V	CKDYZ 403P 25
C9	Ceramic 0.04 25V	CKDYZ 403P 25
C10	Mylar 0.01 50V	CQMA 103K 50
C11	Mylar 410p 50V	CQSA 411K 50
C12	Ceramic 0.04 25V	CKDYZ 403P 25
C13	Electrolytic 10 50V	CEMX 10MF 50V
C14	Ceramic 0.02 25	CKDYZ 203P 25
C15	Ceramic 0.04 25V	CKDYZ 403P 25
C16	Ceramic 0.04 25V	CKDYZ 403P 25
C17	Ceramic 0.04 25V	CKDYZ 403P 25
C18	Ceramic 47p 50V	CCDSL 470K 50
C19	Ceramic 0.04 25V	CKDYZ 403P 25
C20	Mylar 4700p 50V	CQMA 472K 50
C21	Mylar 4700p 50V	CQMA 472K 50
C22	Electrolytic 0.47 50V	CEMX R47MF 50V
C23	Electrolytic 220 6V	CEMX 220MF 6V
C24	Ceramic 0.04 25V	CKDYZ 403P 25
C25	Electrolytic 100 16V	CEMX 100MF 16V

RESISTORS

Symbol	Description	Part No.
R1	Carbon film 22k	RF $\frac{1}{4}$ PS 22K-K
R2	Carbon film 15k	RF $\frac{1}{4}$ PS 15K-K
R3	Carbon film 470	RF $\frac{1}{4}$ PS 470-K
R4	Carbon film 100	RF $\frac{1}{4}$ PS 100-K
R5	Carbon film 2.2k	RF $\frac{1}{4}$ PS 2R2K-K
R6	Carbon film 10k	RF $\frac{1}{4}$ PS 10K-K
R7	Carbon film 3.3k	RF $\frac{1}{4}$ PS 3R3K-K
R8	Carbon film 470	RF $\frac{1}{4}$ PS 470-K
R9	Carbon film 1k	RF $\frac{1}{4}$ PS 1K-K
R10	Carbon film 1k	RF $\frac{1}{4}$ PS 1K-K
R11	Carbon film 4.7k	RF $\frac{1}{4}$ PS 4R7K-K
R12	Carbon film 27k	RF $\frac{1}{4}$ PS 27K-K
R13	Carbon film 1K	RF $\frac{1}{4}$ PS 1K-K
R14	Carbon film 68	RF $\frac{1}{4}$ PS 68-K
R15	Carbon film 4.7k	RF $\frac{1}{4}$ PS 4R7K-K
R16	Carbon film 100k	RF $\frac{1}{4}$ PS 100K-K
R17	Carbon film 27k	RF $\frac{1}{4}$ PS 27K-K
R18	Carbon film 1k	RF $\frac{1}{4}$ PS 1K-K
R19	Carbon film 150k	RF $\frac{1}{4}$ PS 150K-K
R20	Carbon film 4.7k	RF $\frac{1}{4}$ PS 4R7K-K
R21	Carbon film 4.7k	RF $\frac{1}{4}$ PS 4R7K-K
R22	Carbon film 22k	RF $\frac{1}{4}$ PS 22K-K
R23	Carbon film 470	RF $\frac{1}{4}$ PS 470-K
R24	Carbon film 470	RF $\frac{1}{4}$ PS 470-K
R25	Carbon film 100	RF $\frac{1}{4}$ PS 100-K
R26	Carbon film 3.3k	RF $\frac{1}{4}$ PS 3R3K-K
R27	Carbon film 6.8k	RF $\frac{1}{4}$ PS 6R8K-K
R28	Carbon film 100	RF $\frac{1}{4}$ PS 100-K
R29	Carbon film 3.9k	RF $\frac{1}{4}$ PS 3R9K-K
R30	Carbon film 4.7k	RF $\frac{1}{4}$ PS 4R7K-K

COILS AND TRANSFORMERS

Symbol	Description	Part No.
T1	MW RF COIL	T41-008
T2	MW OSC COIL	T43-007
T3	AM IFT	T41-025
T4	AM IFT	T71-025
T5	AM DET IFT	T72-017

SEMICONDUCTORS

Symbol	Description	Part No.
D1	1S188 or FM-1 Diode	
D2	1S188 or FM-1 Diode	
Q1	2SC382 Transistor	
Q2	2SC460-B Transistor	
Q3	2SC460-B Transistor	
Q4	2SC460-B Transistor	
Q5	2SC460-B Transistor	

HEAD AMP UNIT (W21-002)

CAPACITORS

Symbol	Description	Part No.
C1	Electrolytic 22 10V	CEMX 22MF 10V
C2	Electrolytic 22 10V	CEMX 22MF 10V
C3	Electrolytic 4.7 16V	CEMX 4R7MF 16V
C4	Electrolytic 4.7 16V	CEMX 4R7MF 16V
C5	Electrolytic 10 25V	CEMX 10MF 25V
C6	Electrolytic 10 25V	CEMX 10MF 25V
C7	Ceramic 100p 50V	CCDSL 101K 50
C8	Ceramic 100p 50V	CCDSL 101K 50
C9	Ceramic 330p 50V	CCDSL 331K 50
C10	Ceramic 330p 50V	CCDSL 331K 50
C11	Mylar 0.01 50V	CQMA 103K 50
C12	Mylar 0.01 50V	CQMA 103K 50
C13	Mylar 3300p 50V	CQMA 332K 50
C14	Mylar 3300p 50V	CQMA 332K 50
C15	Electrolytic 220 25V	CEMX 220MF 25V

RESISTORS

Symbol	Description	Part No.
R1	Carbon film 1k	RF $\frac{1}{4}$ PS 1K-K
R2	Carbon film 1k	RF $\frac{1}{4}$ PS 1K-K
R3	Carbon film 56k	RF $\frac{1}{4}$ PS 56K-K
R4	Carbon film 56k	RF $\frac{1}{4}$ PS 56K-K
R5	Carbon film 1M	RF $\frac{1}{4}$ PS 1M-K
R6	Carbon film 1M	RF $\frac{1}{4}$ PS 1M-K
R7	Carbon film 390	RF $\frac{1}{4}$ PS 390-K
R8	Carbon film 390	RF $\frac{1}{4}$ PS 390-K
R9	Carbon film 470k	RF $\frac{1}{4}$ PS 470K-K
R10	Carbon film 470k	RF $\frac{1}{4}$ PS 470K-K
R11	Carbon film 56k	RF $\frac{1}{4}$ PS 56K-K
R12	Carbon film 56k	RF $\frac{1}{4}$ PS 56K-K
R13	Carbon film 330k	RF $\frac{1}{4}$ PS 330K-K
R14	Carbon film 330k	RF $\frac{1}{4}$ PS 330K-K
R15	Carbon film 3.3k	RF $\frac{1}{4}$ PS 3R3K-K
R16	Carbon film 3.3k	RF $\frac{1}{4}$ PS 3R3K-K
R17	Carbon film 4.7k	RF $\frac{1}{4}$ PS 4R7K-K
R18	Carbon film 4.7k	RF $\frac{1}{4}$ PS 4R7K-K
R19	Carbon film 10k	RF $\frac{1}{4}$ PS 10K-K
R20	Carbon film 10k	RF $\frac{1}{4}$ PS 10K-K
R21	Carbon film 47k	RF $\frac{1}{4}$ PS 47K-K
R22	Carbon film 47k	RF $\frac{1}{4}$ PS 47K-K
R23	Carbon film 270k	RF $\frac{1}{4}$ PS 270K-K
R24	Carbon film 270k	RF $\frac{1}{4}$ PS 270K-K
R25	Carbon film 22k	RF $\frac{1}{4}$ PS 22K-K
R26	Carbon film 22k	RF $\frac{1}{4}$ PS 22K-K
R27	Carbon film 2.2k	RF $\frac{1}{4}$ PS 2R2K-K
R28	Carbon film 2.2k	RF $\frac{1}{4}$ PS 2R2K-K
R29	Carbon film 12k	RF $\frac{1}{4}$ PS 12K-K
R30	Carbon film 12k	RF $\frac{1}{4}$ PS 12K-K

TRANSISTORS

Symbol	Description	Part No.
Q1	2SC458LG-B	
Q2	2SC458LG-B	
Q3	2SC458LG-B	
Q4	2SC458LG-B	
Q5	2SC458LG-B	
Q6	2SC458LG-B	

DEMI SWITCH UNIT (W26-001) RESISTORS

Symbol	Description			Part No.
R ₁	Carbon film	10k		RF $\frac{1}{2}$ PS 10K-K
R ₂	Carbon film	10k		RF $\frac{1}{2}$ PS 10K-K
R ₃	Carbon film	10k		RF $\frac{1}{2}$ PS 10K-K
R ₄	Carbon film	10k		RF $\frac{1}{2}$ PS 10K-K

SWITCH

Symbol	Description	Part No.
S ₁	Demi Switch	S31-029

DEMI SWITCH UNIT (W26-002) CAPACITORS

Symbol	Description			Part No.
C ₁	Mylar	0.015	50V	CQMA 153K 50
C ₂	Mylar	0.015	50V	CQMA 153K 50
C ₃	Mylar	0.047	50V	CQMA 473K 50
C ₄	Mylar	0.047	50V	CQMA 473K 50
C ₅	Mylar	0.033	50V	CQMA 333K 50
C ₆	Mylar	0.033	50V	CQMA 333K 50
C ₇	Ceramic	220p	50V	CCDSL 221K 50
C ₈	Ceramic	220p	50V	CCDSL 221K 50

RESISTORS

Symbol	Description			Part No.
R ₁	Carbon film	150k		RF $\frac{1}{2}$ PS 150K-K
R ₂	Carbon film	150k		RF $\frac{1}{2}$ PS 150K-K
R ₃	Carbon film	12k		RF $\frac{1}{2}$ PS 12K-K
R ₄	Carbon film	12k		RF $\frac{1}{2}$ PS 12K-K

SWITCH

Symbol	Description	Part No.
S ₁	Demi Switch	S31-016-A

TONE COLOR UNIT (W28-001) CAPACITORS

Symbol	Description			Part No.
C ₁	Electrolytic	10	10V	CEMX 10MF 10V
C ₂	Electrolytic	10	10V	CEMX 10MF 10V
C ₃	Ceramic	47p	50V	CCDSL 470K 50
C ₄	Ceramic	47p	50V	CCDSL 470K 50
C ₅	Ceramic	100p	50V	CCDSL 101K 50
C ₆	Ceramic	100p	50V	CCDSL 101K 50
C ₇	Electrolytic	10	25V	CEMX 10MF 25V
C ₈	Electrolytic	10	25V	CEMX 10MF 25V
C ₉	Electrolytic	47	10V	CEMF 47MF 10V
C ₁₀	Electrolytic	47	10V	CEMX 47MF 10V
C ₁₁	Electrolytic	10	25V	CEMX 10MF 25V
C ₁₂	Electrolytic	10	25V	CEMX 10MF 25V
C ₁₃	Mylar	3300p	50V	CQMA 332K 50

C ₁₄	Mylar	3300p	50V	CQMA 332K 50
C ₁₅	Mylar	8200p	50V	CQMA 822K 50
C ₁₆	Mylar	8200p	50V	CQMA 822K 50
C ₁₇	Mylar	0.082	50V	CQMA 823K 50
C ₁₈	Mylar	0.082	50V	CQMA 823K 50

RESISTORS

Symbol	Description			Part No.
R ₁	Carbon film	470k		RF $\frac{1}{2}$ PS 470K-K
R ₂	Carbon film	470k		RF $\frac{1}{2}$ PS 470K-K
R ₃	Carbon film	2.7k		RF $\frac{1}{2}$ PS 2R7K-K
R ₄	Carbon film	2.7k		RF $\frac{1}{2}$ PS 2R7K-K
R ₅	Carbon film	33k		RF $\frac{1}{2}$ PS 33K-K
R ₆	Carbon film	33k		RF $\frac{1}{2}$ PS 33K-K
R ₇	Carbon film	47k		RF $\frac{1}{2}$ PS 47K-K
R ₈	Carbon film	47k		RF $\frac{1}{2}$ PS 47K-K
R ₉	Carbon film	10k		RF $\frac{1}{2}$ PS 10K-K
R ₁₀	Carbon film	10k		RF $\frac{1}{2}$ PS 10K-K
R ₁₁	Carbon film	2.2k		RF $\frac{1}{2}$ PS 2R2K-K
R ₁₂	Carbon film	2.2k		RF $\frac{1}{2}$ PS 2R2K-K
R ₁₃	Carbon film	15k		RF $\frac{1}{2}$ PS 15K-K
R ₁₄	Carbon film	15k		RF $\frac{1}{2}$ PS 15K-K
R ₁₅	Carbon film	3.9k		RF $\frac{1}{2}$ PS 3R9K-K
R ₁₆	Carbon film	3.9k		RF $\frac{1}{2}$ PS 3R9K-K
R ₁₇	Carbon film	6.8k		RF $\frac{1}{2}$ PS 6R8K-K
R ₁₈	Carbon film	6.8k		RF $\frac{1}{2}$ PS 6R8K-K
R ₁₉	Carbon film	2.7k		RF $\frac{1}{2}$ PS 2R7K-K
R ₂₀	Carbon film	2.7k		RF $\frac{1}{2}$ PS 2R7K-K
R ₂₁	Carbon film	6.8k		RF $\frac{1}{2}$ PS 6R8K-K
R ₂₂	Carbon film	6.8k		RF $\frac{1}{2}$ PS 6R8K-K
R ₂₃	Carbon film	6.8k		RF $\frac{1}{2}$ PS 6R8K-K
R ₂₄	Carbon film	6.8k		RF $\frac{1}{2}$ PS 6R8K-K

TRANSISTORS

Symbol	Description	Part No.
Q ₁	2SC458LG-B	
Q ₂	2SC458LG-B	
Q ₃	2SC458LG-B	
Q ₄	2SC458LG-B	

CONTROL AMP UNIT (W22-002) CAPACITORS

Symbol	Description			Part No.
C ₁	Electrolytic	100	25V	CEMX 100M 25V
C ₂	Electrolytic	100	25V	CEMX 100M 25V
C ₃	Electrolytic	10	25V	CEMX 10MF 25V
C ₄	Electrolytic	10	25V	CEMX 10MF 25V
C ₅	Electrolytic	47	25V	CEMX 47MF 25V
C ₆	Electrolytic	47	25V	CEMX 47MF 25V
C ₇	Electrolytic	10	25V	CEMX 10MF 25V
C ₈	Electrolytic	10	25V	CEMX 10MF 25V
C ₉	Mylar	0.047	50V	CQMA 473M 50
C ₁₀	Mylar	0.047	50V	CQMA 473M 50
C ₁₁	Mylar	0.047	50V	CQMA 473M 50
C ₁₂	Mylar	0.047	50V	CQMA 473M 50
C ₁₃	Mylar	3300p	50V	CQMA 332M 50
C ₁₄	Mylar	3300p	50V	CQMA 332M 50
C ₁₅	Electrolytic	10	25V	CEMX 10MF 25V
C ₁₆	Electrolytic	10	25V	CEMX 10MF 25V
C ₁₇	Electrolytic	1	25V	CEMX 1MF 25V
C ₁₈	Electrolytic	1	25V	CEMX 1MF 25V
C ₁₉	Electrolytic	47	25V	CEMX 47MF 25V

C20	Electrolytic	47	25V	CEMX 47MF 25V
C21	Electrolytic	100	25V	CEMX 100MF 25V
C22	Electrolytic	100	25V	CEMX 100MF 25V
C23	Ceramic	100p	50V	CCDSL 101K 50
C24	Ceramic	100p	50V	CCDSL 101K 50

RESISTORS

Symbol	Description	Part No.
R1	Carbon film 1k	RF $\frac{1}{2}$ PS 1K-K
R2	Carbon film 1k	RF $\frac{1}{2}$ PS 1K-K
R3	Carbon film 47k	RF $\frac{1}{2}$ PS 47K-K
R4	Carbon film 47k	RF $\frac{1}{2}$ PS 47K-K
R5	Carbon film 33k	RF $\frac{1}{2}$ PS 33K-K
R6	Carbon film 33k	RF $\frac{1}{2}$ PS 33K-K
R7	Carbon film 150k	RF $\frac{1}{2}$ PS 150K-K
R8	Carbon film 150k	RF $\frac{1}{2}$ PS 150K-K
R9	Carbon film 3.9k	RF $\frac{1}{2}$ PS 3R9K-K
R10	Carbon film 3.9k	RF $\frac{1}{2}$ PS 3R9K-K
R11	Carbon film 1.2k	RF $\frac{1}{2}$ PS 1R2K-K
R12	Carbon film 1.2k	RF $\frac{1}{2}$ PS 1R2K-K
R13	Carbon film 6.8k	RF $\frac{1}{2}$ PS 6R8K-K
R14	Carbon film 6.8k	RF $\frac{1}{2}$ PS 6R8K-K
R15	Carbon film 10k	RF $\frac{1}{2}$ PS 10K-K
R16	Carbon film 10k	RF $\frac{1}{2}$ PS 10K-K
R17	Carbon film 1k	RF $\frac{1}{2}$ PS 1K-K
R18	Carbon film 1k	RF $\frac{1}{2}$ PS 1K-K
R19	Carbon film 10k	RF $\frac{1}{2}$ PS 10K-K
R20	Carbon film 10k	RF $\frac{1}{2}$ PS 10K-K
R21	Carbon film 4.7k	RF $\frac{1}{2}$ PS 4R7K-K
R22	Carbon film 4.7k	RF $\frac{1}{2}$ PS 4R7K-K
R23	Carbon film 330k	RF $\frac{1}{2}$ PS 330K-K
R24	Carbon film 330k	RF $\frac{1}{2}$ PS 330K-K
R25	Carbon film 150k	RF $\frac{1}{2}$ PS 150K-K
R26	Carbon film 150k	RF $\frac{1}{2}$ PS 150K-K
R27	Carbon film 10k	RF $\frac{1}{2}$ PS 10K-K
R28	Carbon film 10k	RF $\frac{1}{2}$ PS 10K-K
R29	Carbon film 2.2k	RF $\frac{1}{2}$ PS 2R2K-K
R30	Carbon film 2.2k	RF $\frac{1}{2}$ PS 2R2K-K
R31	Carbon film 1.8k	RF $\frac{1}{2}$ PS 1R8K-K
R32	Carbon film 1.8k	RF $\frac{1}{2}$ PS 1R8K-K

POTENTIOMETERS

Symbol	Description	Part No.
VR1	BASS CONTROL (100K Ω -A)	C82-045
VR2	TREBLE CONTROL (100K Ω -A)	C82-045

TRANSISTORS

Symbol	Description	Part No.
Q1	2SC458LG-B	
Q2	2SC458LG-B	
Q3	2SC458LG-B	
Q4	2SC458LG-B	

MAIN AMP UNIT (W15-052)

CAPACITORS

Symbol	Description	Part No.
C1	Electrolytic 100 25V	CEMX 100MF25V
C2	Electrolytic 100 25V	CEMX 100MF25V
C3	Electrolytic 10 10V	CEMX 10MF10V
C4	Electrolytic 10 10V	CEMX 10MF10V
C5	Electrolytic 22 25V	CEMX 22MF25V

Symbol	Description	Part No.
C6	Electrolytic 22 25V	CEMX 22MF 25V
C7	Electrolytic 47 3V	CEMX 47MF 3V
C8	Electrolytic 47 3V	CEMX 47MF 3V
C9	Ceramic 56p 50V	CKDYZ 560K 50
C10	Ceramic 56p 50V	CKDYZ 560K 50
C11	Electrolytic 100 3V	CEMX 100MF 3V
C12	Electrolytic 100 3V	CEMX 100MF 3V
C13	Electrolytic 100 50V	CEMX 100MF 3V
C14	Electrolytic 100 50V	CEMX 100MF 3V
C15	Ceramic 0.01 50V	CKDYZ 103M 50
C16	Ceramic 0.01 50V	CKDYZ 103M 50
C17	Ceramic 100p 50V	CCDSL 101K 50
C18	Ceramic 100p 50V	CCDSL 101K 50
C19	Ceramic 300p 50V	CCDSL 301K 50
C20	Ceramic 300p 50V	CCDSL 301K 50

RESISTORS

Symbol	Description	Part No.
R1	Carbon film 150k	RF $\frac{1}{2}$ PS 150K-K
R2	Carbon film 150k	RF $\frac{1}{2}$ PS 150K-K
R3	Carbon film 15k	RF $\frac{1}{2}$ PS 15K-K
R4	Carbon film 15k	RF $\frac{1}{2}$ PS 15K-K
R5	Carbon film 220k	RF $\frac{1}{2}$ PS 220K-K
R6	Carbon film 220k	RF $\frac{1}{2}$ PS 220K-K
R7	Carbon film 22k	RF $\frac{1}{2}$ PS 22K-K
R8	Carbon film 22k	RF $\frac{1}{2}$ PS 22K-K
R9	Carbon film 4.7k	RF $\frac{1}{2}$ PS 4R7K-K
R10	Carbon film 4.7k	RF $\frac{1}{2}$ PS 4R7K-K
R11	Carbon film 470	RF $\frac{1}{2}$ PS 470-K
R12	Carbon film 470	RF $\frac{1}{2}$ PS 470-K
R13	Carbon film 150	RF $\frac{1}{2}$ PS 150-K
R14	Carbon film 150	RF $\frac{1}{2}$ PS 150-K
R15	Carbon film 82k	RF $\frac{1}{2}$ PS 82K-K
R16	Carbon film 82k	RF $\frac{1}{2}$ PS 82K-K
R17	Carbon film 3.3k	RF $\frac{1}{2}$ PS 3R3K-K
R18	Carbon film 3.3k	RF $\frac{1}{2}$ PS 3R3K-K
R19	Carbon film 68	RF $\frac{1}{2}$ PS 68-K
R20	Carbon film 68	RF $\frac{1}{2}$ PS 68-K
R21	Carbon film 4.7k	RF $\frac{1}{2}$ PS 4R7K-K
R22	Carbon film 4.7k	RF $\frac{1}{2}$ PS 4R7K-K
R23	Carbon film 6.8k	RF $\frac{1}{2}$ PS 6R8K-K
R24	Carbon film 6.8k	RF $\frac{1}{2}$ PS 6R8K-K
R25	Carbon film 220	RF $\frac{1}{2}$ PS 220-K
R26	Carbon film 220	RF $\frac{1}{2}$ PS 220-K
R27	Carbon film 10	RF $\frac{1}{2}$ PS 10-K
R28	Carbon film 10	RF $\frac{1}{2}$ PS 10-K
R29	Carbon film 220	RF $\frac{1}{2}$ PS 220-K
R30	Carbon film 220	RF $\frac{1}{2}$ PS 220-K
R31	Wire wound 0.5 5W	R05B 0R5-K
R32	Wire wound 0.5 5W	R05B 0R5-K
R33	Wire wound 0.5 5W	R05B 0R5-K
R34	Wire wound 0.5 5W	R05B 0R5-K
R35	Carbon film 22	RF $\frac{1}{2}$ PS 22-K
R36	Carbon film 22	RF $\frac{1}{2}$ PS 22-K
R37	Carbon film 15k	RF $\frac{1}{2}$ PS 15K-K
R38	Carbon film 15k	RF $\frac{1}{2}$ PS 15K-K
R39	Carbon film 15k	RF $\frac{1}{2}$ PS 15K-K
R40	Carbon film 15k	RF $\frac{1}{2}$ PS 15K-K

POTENTIOMETERS

Symbol	Description	Part No.
VR1	Bias Control (50K Ω -B) Semi-fixed	C92-044
VR2	Bias Control (50K Ω -B) Semi-fixed	C92-044
VR3	Bias Control (50 Ω -B) Semi-fixed	C92-046
VR4	Bias Control (50 Ω -B) Semi-fixed	C92-046

SEMICONDUCTORS

Symbol	Description	Part No.
D1	STV-3 Varistor	
D2	STV-3 Varistor	
Q1	2SC870 Transistor	
Q2	2SC870 Transistor	
Q3	2SC627 Transistor	
Q4	2SC627 Transistor	
Q5	2SC484-Y Transistor	
Q6	2SC484-Y Transistor	
Q7	2SA484-Y Transistor	
Q8	2SA484-Y Transistor	
Q9	2SD218 Transistor	
Q10	2SD218 Transistor	
Q11	2SD218 Transistor	
Q12	2SD218 Transistor	

OTHER

Symbol	Description	Part No.
	Heat sink	M14-048
	Mylar insulator	E32-039
	Insulator bush	E32-039

DEMI SWITCH UNIT (W26-003) SWITCH

Symbol	Description	Part No.
S1	Demi switch	S31-030

MIC AMP UNIT (W21-003) CAPACITORS

Symbol	Description	No.	Part
C1	Electrolytic 10 10V	10	CEMX 10MF 10V
C2	Electrolytic 10 10V	10	CEMX 10MF 10V
C3	Ceramic 30p 50V	30p	CCDSL 300K 50
C4	Ceramic 30p 50V	30p	CCDSL 300K 50
C5	Ceramic 100p 50V	100p	CCDSL 101K 50
C6	Ceramic 100p 50V	100p	CCDSL 101K 50
C7	Electrolytic 0.47 50V	0.47	CEMX R47M50V
C8	Electrolytic 0.47 50V	0.47	CEMX R47M50V
C9	Electrolytic 33 6V	33	CEMX 33MF 6VV
C10	Electrolytic 33 6V	33	CEMX 33MF 6VV
C11	Electrolytic 10 10V	10	CEMX 10MF 10V
C12	Electrolytic 10 10V	10	CEMX 10MF 10V

RESISTORS

Symbol	Description	Part No.
R1	Carbon film 1k	RF1PS 1K-K
R2	Carbon film 1k	RF1PS 1K-K
R3	Carbon film 150k	RF1PS 150K-K
R4	Carbon film 150k	RF1PS 150K-K
R5	Carbon film 220k	RF1PS 220K-K
R6	Carbon film 220k	RF1PS 220K-K
R7	Carbon film 120k	RF1PS 120K-K
R8	Carbon film 120k	RF1PS 120K-K
R9	Carbon film 390	RF1PS 390-K

R10	Carbon film	390	RF1PS 390-K
R11	Carbon film	470k	RF1PS 470K-K
R12	Carbon film	470K	RF1PS 470K-K
R13	Carbon film	15k	RF1PS 15K-K
R14	Carbon film	15k	RF1PS 15K-K
R15	Carbon film	2.7k	RF1PS 2R7K-K
R16	Carbon film	2.7k	RF1PS 2R7K-K
R19	Carbon film	27k	RF1PS 27K-K
R20	Carbon film	27k	RF1PS 27K-K
R21	Carbon film	56k	RF1PS 56K-K
R22	Carbon film	56k	RF1PS 56K-K
R23	Carbon film	2.2k	RF1PS 2R2K-K
R24	Carbon film	2.2k	RF1PS 2R2K-K

TRANSISTORS

Symbol	Description	Part No.
Q1	2SC871-GR or BL	
Q2	2SC871-GR or BL	
Q3	2SC870	
Q4	2SC870	

REVERB AMP UNIT (W28-002) CAPACITORS

Symbol	Description	Part No.
C1	Electrolytic 0.1 25V	CSYA R1MF 25V
C2	Electrolytic 0.1 25V	CSYA R1MF 25V
C3	Ceramic 100p 50V	CCDSL 101K 50
C4	Ceramic 100p 50V	CCDSL 101K 50
C5	Electrolytic 10 25V	CEMX 10MF 25V
C6	Electrolytic 10 25V	CEMX 10MF 25V
C7	Mylar 0.033 50V	CQMA 333K 50
C8	Electrolytic 10 25V	CEMX 10MF 25V
C9	Electrolytic 33 50V	CEMX 33MF 50V
C10	Ceramic 330p 50V	CCDSL 331K 50
C11	Electrolytic 33 50V	CEMX 33MF 50V
C12	Mylar 0.022 50V	CQMA 223K 50
C13	Mylar 0.022 50V	CQMA 223K 50
C14	Electrolytic 10 25V	CEMX 10MF 25V
C15	Electrolytic 10 25V	CEMX 10MF 25V
C16	Mylar 0.022 50V	CQMA 223K 50
C17	Mylar 0.022 50V	CQMA 223K 50
C18	Electrolytic 0.1 25V	CSYA R1MF 25V
C19	Electrolytic 0.1 25V	CSYA R1MF 25V

RESISTORS

Symbol	Description	Part No.
R1	Carbon film 1k	RF1PS 1K-K
R2	Carbon film 1k	RF1PS 1K-K
R3	Carbon film 330k	RF1PS 330K-K
R4	Carbon film 330k	RF1PS 330K-K
R5	Carbon film 470k	RF1PS 470K-K
R6	Carbon film 470k	RF1PS 470K-K
R7	Carbon film 10k	RF1PS 10K-K
R8	Carbon film 10k	RF1PS 10K-K
R9	Carbon film 220k	RF1PS 220K-K
R10	Carbon film 220k	RF1PS 220K-K
R11	Carbon film 5.6k	RF1PS 5R6K-K
R12	Carbon film 5.6k	RF1PS 5R6K-K
R13	Carbon film 330k	RF1PS 330K-K
R14	Carbon film 22k	RF1PS 22K-K
R15	Carbon film 3.3k	RF1PS 3R3K-K
R16	Carbon film 220	RF1PS 220-K

R17	Carbon film	3.9k	RF $\frac{1}{4}$ PS 3R9K-K
R18	Carbon film	2.2k	RF $\frac{1}{4}$ PS 2R2K-K
R19	Carbon film	56k	RF $\frac{1}{4}$ PS 56K-K
R20	Carbon film	5.6k	RF $\frac{1}{4}$ PS 5R6K-K
R21	Carbon film	1k	RF $\frac{1}{4}$ PS 1K-K
R22	Carbon film	270	RF $\frac{1}{4}$ PS 270-K
R23	Carbon film	150	RF $\frac{1}{4}$ PS 150-K
R24	Carbon film	39	RF $\frac{1}{4}$ PS 39-K
R25	Carbon film	39	RF $\frac{1}{4}$ PS 39-K
R26	Carbon film	47	RF $\frac{1}{4}$ PS 47-K
R27	Carbon film	100	RF $\frac{1}{4}$ PS 100-K
R28	Carbon film	1k	RF $\frac{1}{4}$ PS 1K-K
R29	Carbon film	390k	RF $\frac{1}{4}$ PS 390K-K
R30	Carbon film	120k	RF $\frac{1}{4}$ PS 120K-K
R31	Carbon film	22k	RF $\frac{1}{4}$ PS 22K-K
R32	Carbon film	10k	RF $\frac{1}{4}$ PS 10K-K
R33	Carbon film	560	RF $\frac{1}{4}$ PS 560-K
R34	Carbon film	10k	RF $\frac{1}{4}$ PS 10K-K
R35	Carbon film	10k	RF $\frac{1}{4}$ PS 10K-K
R36	Carbon film	390k	RF $\frac{1}{4}$ PS 390K-K
R37	Carbon film	390k	RF $\frac{1}{4}$ PS 390K-K
R38	Carbon film	27k	RF $\frac{1}{4}$ PS 27K-K
R39	Carbon film	27k	RF $\frac{1}{4}$ PS 27K-K
R30	Carbon film	10k	RF $\frac{1}{4}$ PS 10K-K
R41	Carbon film	10k	RF $\frac{1}{4}$ PS 10K-K
R42	Carbon film	680	RF $\frac{1}{4}$ PS 680-K
R43	Carbon film	680	RF $\frac{1}{4}$ PS 680-K

TRANSISTORS

Symbol	Description	Part No.
Q1	2SC870-Y	
Q2	2SC870-Y	
Q3	2SC870-Y	
Q4	2SC734-O	
Q5	2SC734P-Y	
Q6	2SA561P-O	
Q7	2SC870-Y	
Q8	2SC870-Y	

POWER SUPPLY UNIT (W16-028) CAPACITORS

Symbol	Description	Part No.
C1	Electrolytic 100 50V	CEMX 100MF 50V
C2	Ceramic 100p 50V	CCDSL 101K 50
C3	Electrolytic 100 35V	CEMX 100MF 35V
C4	Electrolytic 220 25V	CEMX 220MF 25V
C5	Electrolytic 100 25V	CEMX 100MF 25V
C6	Electrolytic 100 26V	CEMX 100MF 25V
C7	Electrolytic 220 16V	CEMX 220MF 16V
C8	Ceramic 0.01 DC 1.4KV	C43-003
C9	Ceramic 0.01 DC 1.4KV	C43-003

RESISTORS

Symbol	Description	Part No.
R1	Carbon film 4.7k	RF $\frac{1}{4}$ PS 4R7K-K
R2	Carbon film 150k	RF $\frac{1}{4}$ PS 150K-K
R3	Carbon film 33k	RF $\frac{1}{4}$ PS 33K-K
R4	Carbon film 15k	RF $\frac{1}{4}$ PS 15K-K
R5	Wire wound 680 2W	RO2 680-K
R6	Carbon film 3.9k	RF $\frac{1}{4}$ PS 3R9K-K
R7	Carbon film 33k	RF $\frac{1}{4}$ PS 33K-K
R8	Carbon film 18k	RF $\frac{1}{4}$ PS 18K-K
R9	Carbon film 3.9k	RF $\frac{1}{4}$ PS 3R9K-K
R10	Wire wound 470 1W	RO1 470-K
R11	Carbon film 47	RF $\frac{1}{4}$ PS 47-K
R12	Carbon film 10	RF $\frac{1}{4}$ PS 10-K

SEMICONDUCTORS

Symbol	Description	Part No.
D1	1S1850 Diode	
D2	1S1850 Diode	
D3	1S338 Diode	
Q1	2SC627 Transistor	
Q2	2SC485 Transistor	
Q3	2SC968 Transistor	
Q4	2SC971 Transistor	

OTHER

Symbol	Description	Part No.
	Heat sink	M14-024

POWER SUPPLY UNIT (W16-029) CAPACITORS

Symbol	Description	Part No.
C1	Ceramic 0.01 DC 1.4KV	C43-003
C2	Ceramic 0.01 DC 1.4KV	C43-003
C3	Ceramic 0.01 DC 1.4KV	C43-003
C4	Ceramic 0.01 DC 1.4KV	C43-003

DIODES

Symbol	Description	Part No.
D1	SR3AM-8	
D2	SR3AM-8	
D3	SR3AM-8	
D4	SR3AM-8	

PIONEER ELECTRONIC CORPORATION

15-5, 4-Chome, Ohmori-nishi, Ohta-ku, Tokyo, Japan

PIONEER ELECTRONICS U.S.A. CORPORATION

140 Smith St., Farmingdale, L.I., N.Y. 11735, U.S.A.

PIONEER ELECTRONIC (EUROPE) NV

Frankrijklei 64-68, 2000 Antwerp, Belgium

SX-9000

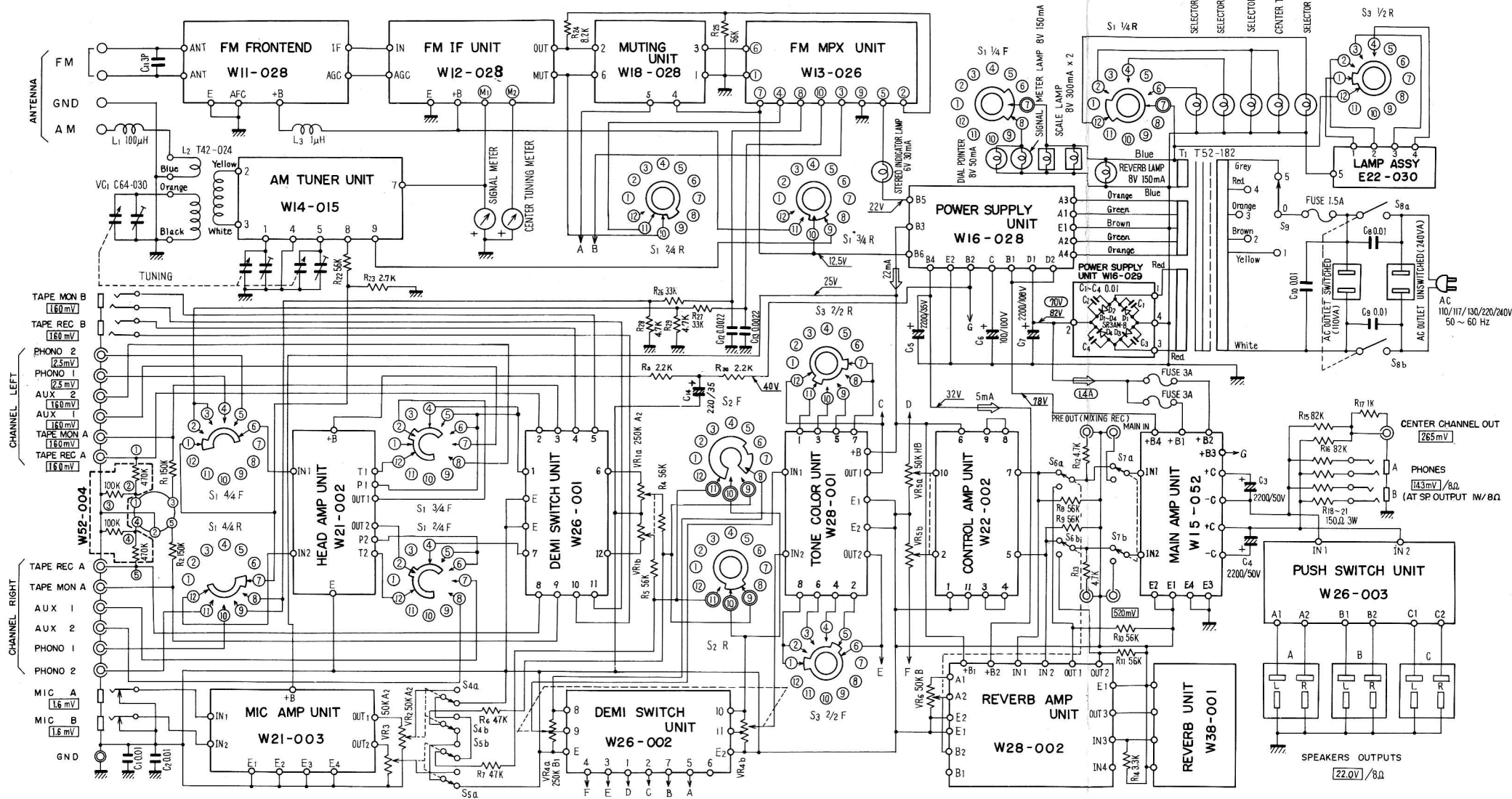

- S1 SELECTOR SWITCH (S13-038)
 1. A M
 2. FM MONO
 3. FM AUTO
 4. PHONO 1
 5. PHONO 2
 6. AUX 1
 7. AUX 2
- S2 MODE SWITCH (S14-035)
 1. REV
 2. ST
 3. LT
 4. RT
 5. L + R
- S3 TONE COLOR SWITCH (S15-035)
 1. VIVID
 2. BASS
 3. FLAT
 4. SOFT
- S4 MIC A SWITCH (VR2)

OFF ↔ ON
- S5 MIC B SWITCH (VR3)

OFF ↔ ON
- S6 REVERB SWITCH (VR6)

OFF ↔ ON
- S7 INTERCUPLED SWITCH (S41-022)

INTERCUPLED

↔ PRE & MAIN SEPARATED
- S8 POWER SWITCH (S11-030)

OFF ↔ ON
- S9 LINE VOLTAGE SELECTOR (S11-018)

OFF 110V/120V/130V/220V/240V
- VR1a SOURCE VOLUME (C88-010)
- VR1b MASTER VOLUME (C88-010)
- VR2 MIC A VOLUME (C85-056)
- VR3 MIC B VOLUME (C85-056)
- VR5 BALANCE VOLUME (C85-052)
- VR6 REVERB VOLUME (C85-055)

← D.C. CURRENT
 A ----- AT NO SIGNAL INPUT
 (A) ----- AT 60 WATTS OUTPUT
 ← D.C. VOLTAGE
 V ----- AT NO SIGNAL INPUT
 (V) ----- AT 60 WATT OUTPUT
 [V] ----- INPUT OR OUTPUT VOLTAGE ACQUIRED
 75 WATTS OUTPUT AT 1 K Hz (R.M.S)

SECTION	ITEM NO.	VACANT
1	R R1 ~ R29	R30 ~
2	C C1 ~ C13	C14 ~
3	L L1 ~ L3	L4 ~

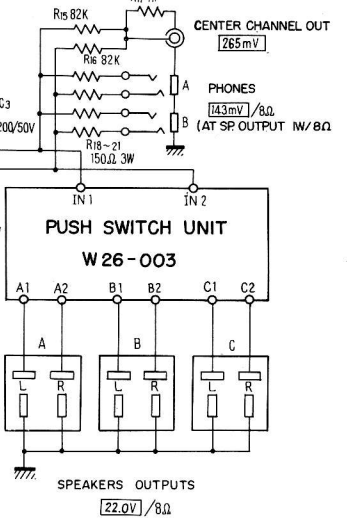

SPEAKERS OUTPUTS
 22.0V / 8Ω

FM FRONT-END

W11-028

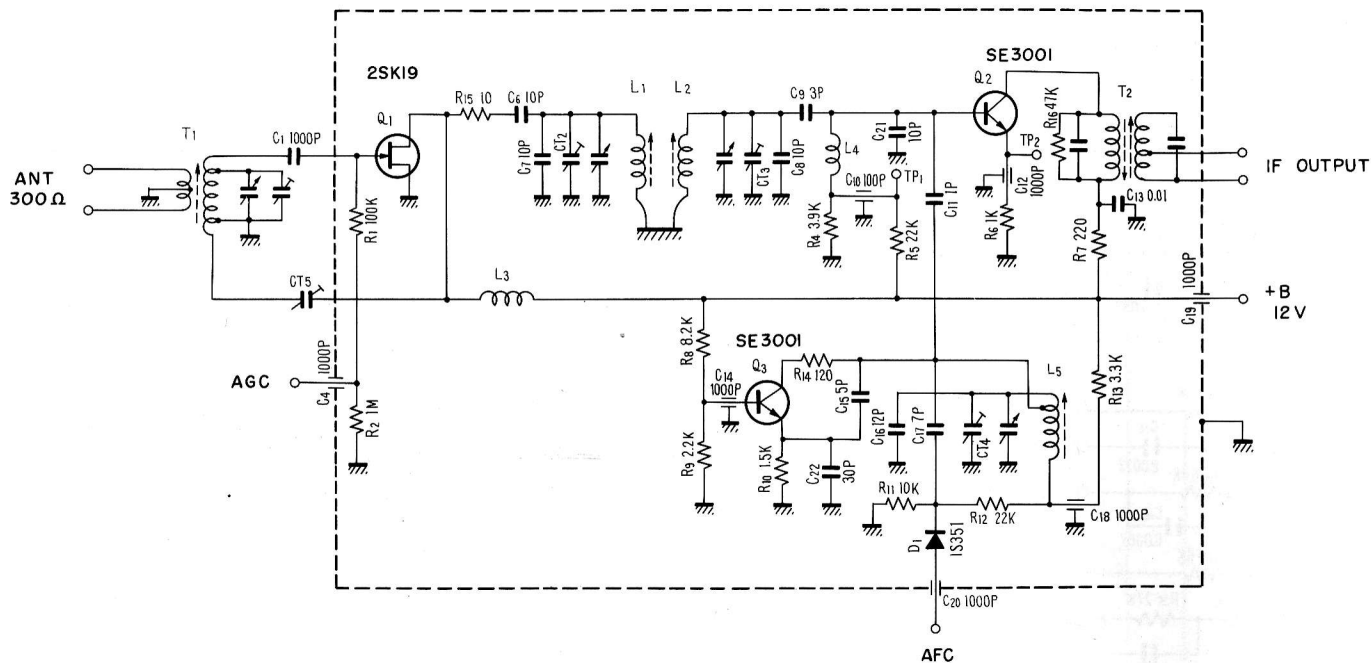

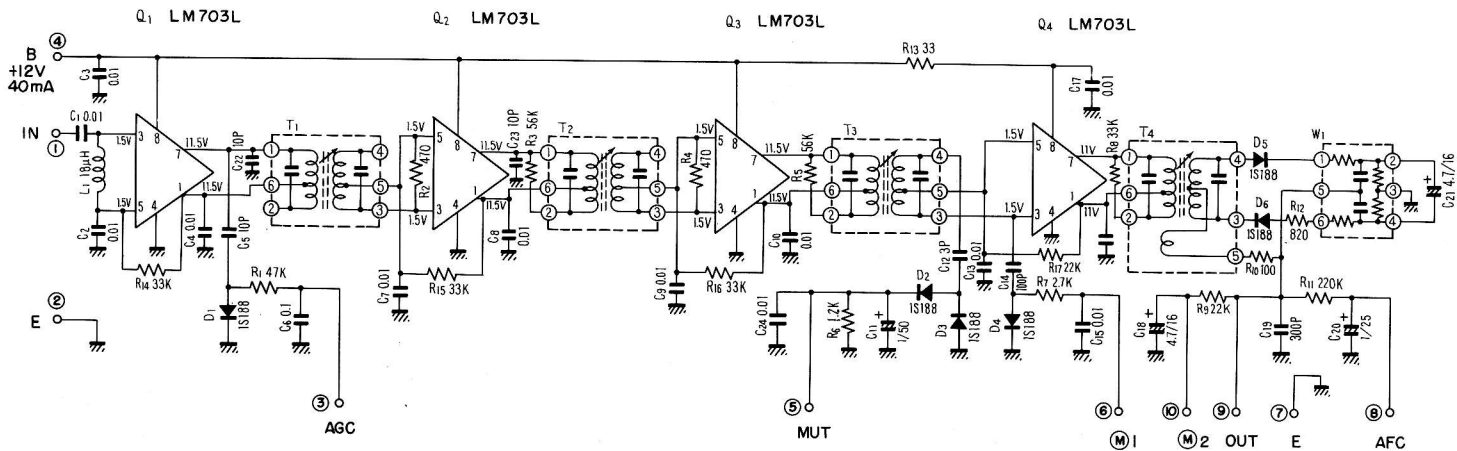

IC Q1 ~ Q4

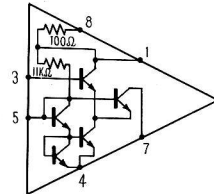

MPX UNIT

W13-026

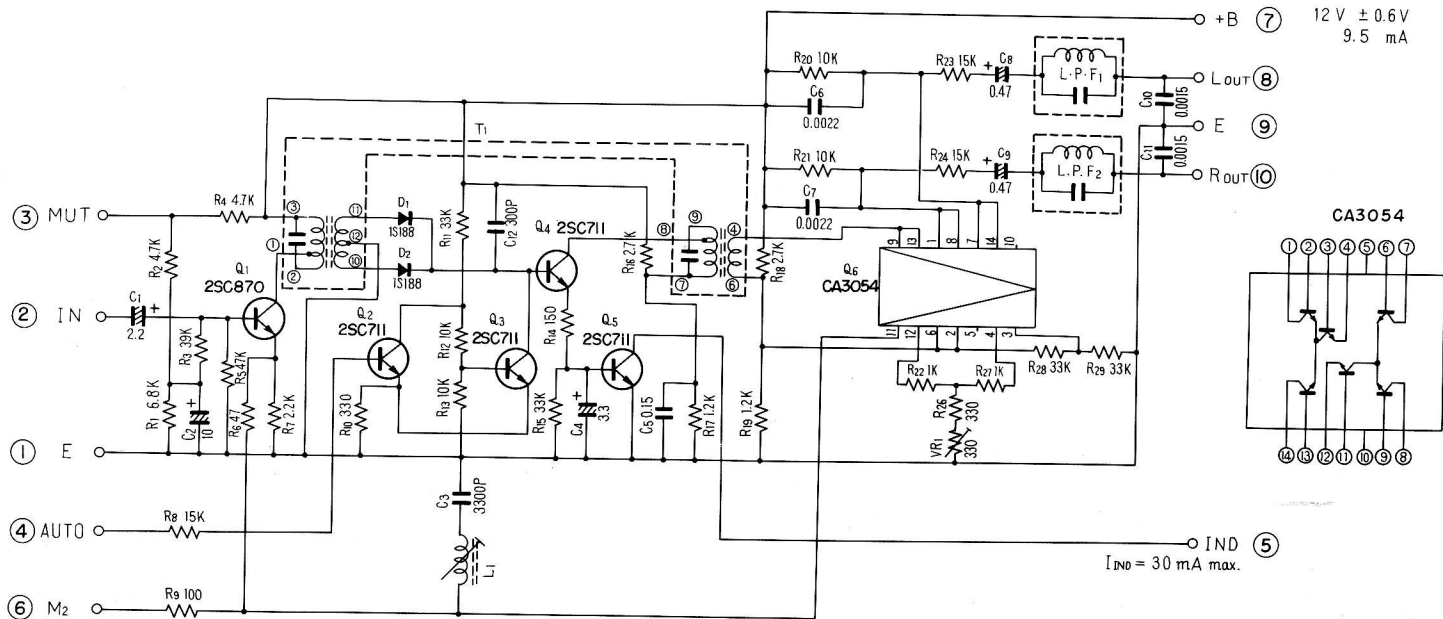

AM TUNER UNIT

W14 - 015

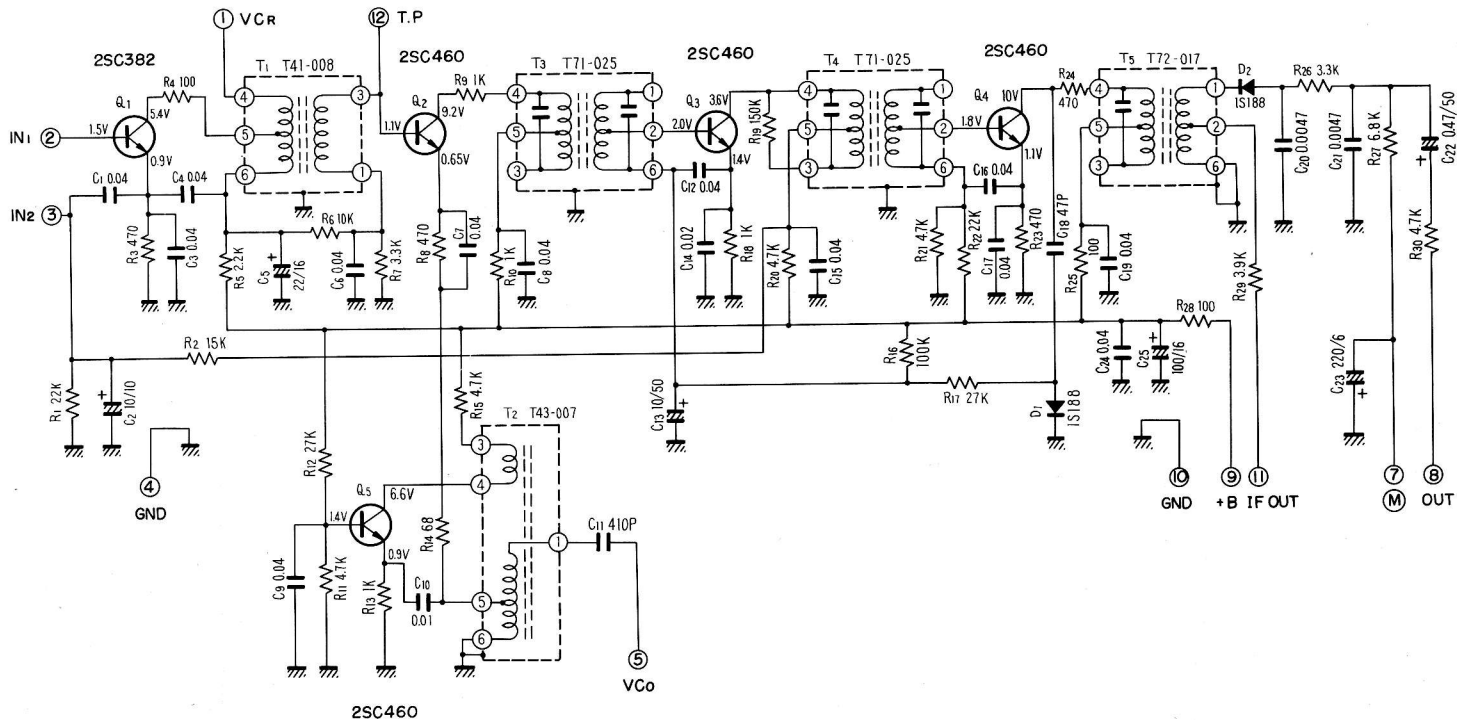

SX-9000

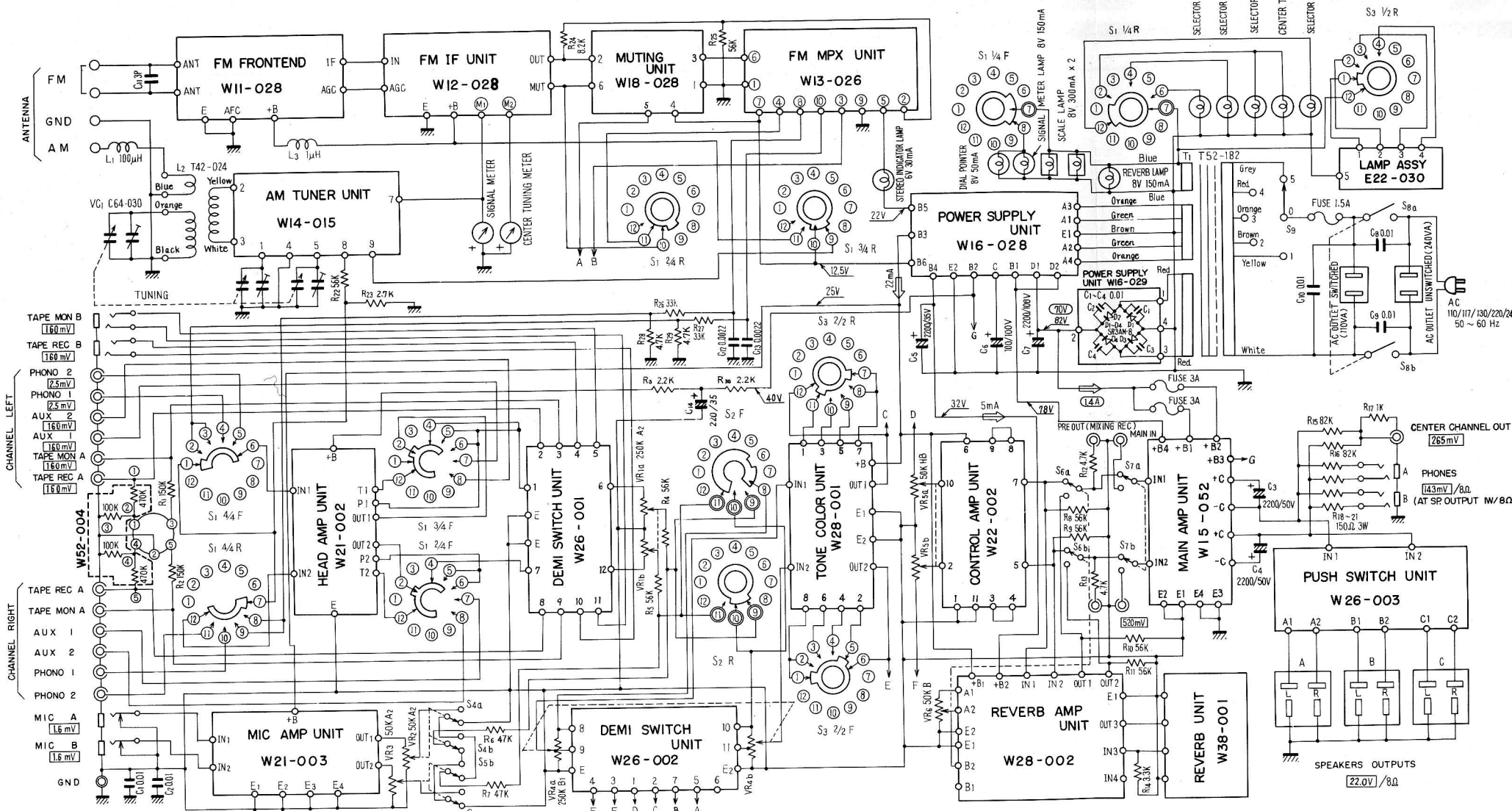

- S1 SELECTOR SWITCH (S13-038)
 - 1. A M
 - 2. FM MONO
 - 3. FM AUTO
 - 4. PHONO 1
 - 5. PHONO 2
 - 6. AUX 1
 - 7. AUX 2
- S2 MODE SWITCH (S14-035)
 - 1. REV
 - 2. ST
 - 3. LT
 - 4. RT
 - 5. L + R
- S3 TONE COLOR SWITCH (S15-035)
 - 1. VIVID
 - 2. BASS
 - 3. FLAT
 - 4. SOFT
- S4 MIC A SWITCH (VR2)
 - OFF → ON
- S5 MIC B SWITCH (VR3)
 - OFF → ON
- S6 REVERB SWITCH (VR6)
 - OFF → ON
- S7 INTERCUPLED SWITCH (S41-022)
 - INTERCUPLED
 - ← PRE & MAIN SEPARATED
- S8 POWER SWITCH (S11-030)
 - OFF → ON
- S9 LINE VOLTAGE SELECTOR (S11-018)
 - OFF / 110V / 120V / 130V / 220V / 240V

- ← D.C. CURRENT
- A ---- AT NO SIGNAL INPUT
- Ⓜ ---- AT 60 WATTS OUTPUT
- D.C. VOLTAGE
- V ---- AT NO SIGNAL INPUT
- Ⓜ ---- AT 60 WATT OUTPUT
- Ⓜ ---- INPUT OR OUTPUT VOLTAGE ACQUIRED 75 WATTS OUTPUT AT 1 K.Hz (R.M.S)

SECTION	ITEM NO.	VACANT
1	R R1 ~ R29	R30 ~
2	C C1 ~ C13	C14 ~
3	L L1 ~ L3	L4 ~

SPEAKERS OUTPUTS
22.0V / 8Ω

HEAD AMP UNIT

W21-002

Q1 ~ Q6 2SC871 or 2SC458LG

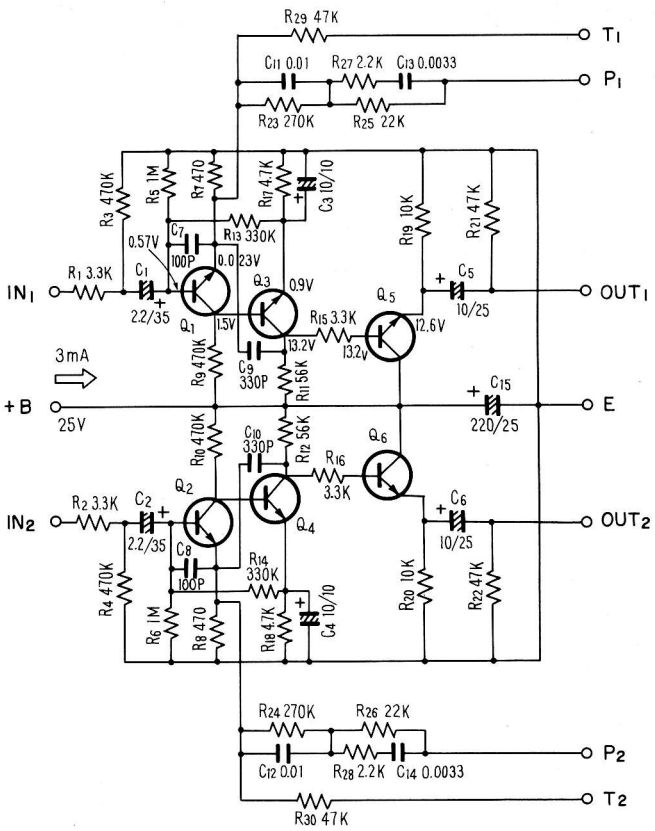

MIC AMP UNIT

W21-003

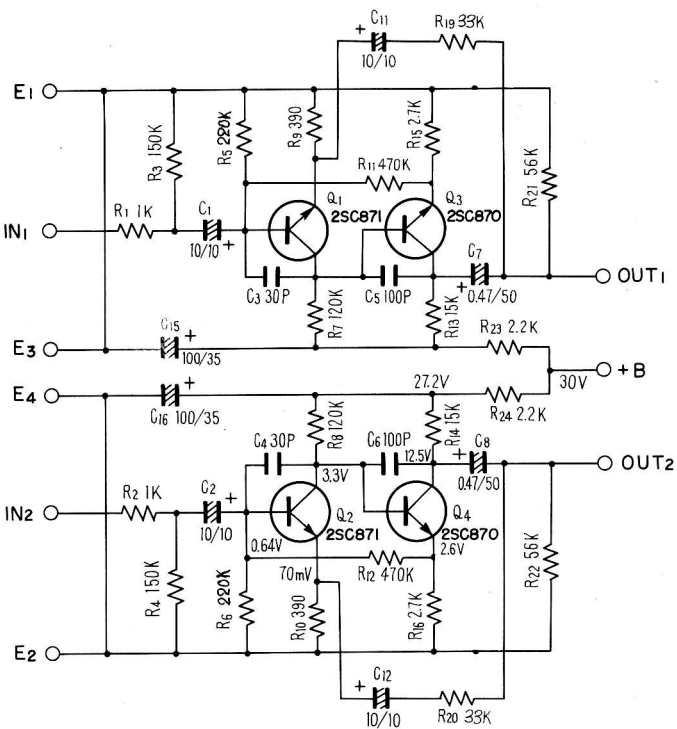

DEMI SWITCH UNIT
W26-001

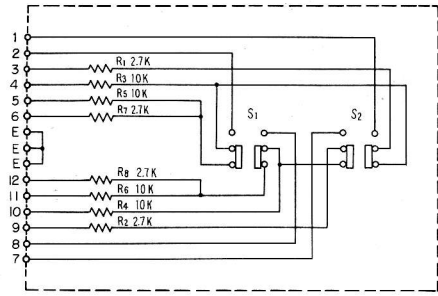

S1 : TAPE MONITOR A OFF ↔ ON
S2 : TAPE MONITOR B OFF ↔ ON

DEMI SWITCH UNIT
W26-002

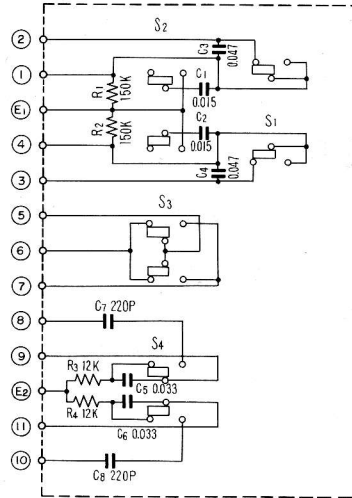

S1 : LOW CUT FILTER OFF ↔ ON
S2 : HIGH CUT FILTER OFF ↔ ON
S3 : MUTING OFF ↔ ON
S4 : LOUDNESS OFF ↔ ON

REVERB UNIT
W38-001

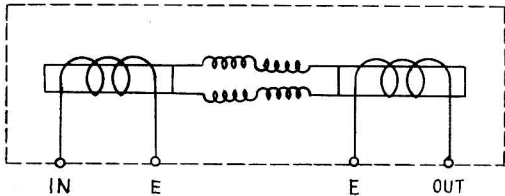

TONE COLOR UNIT
W28-001

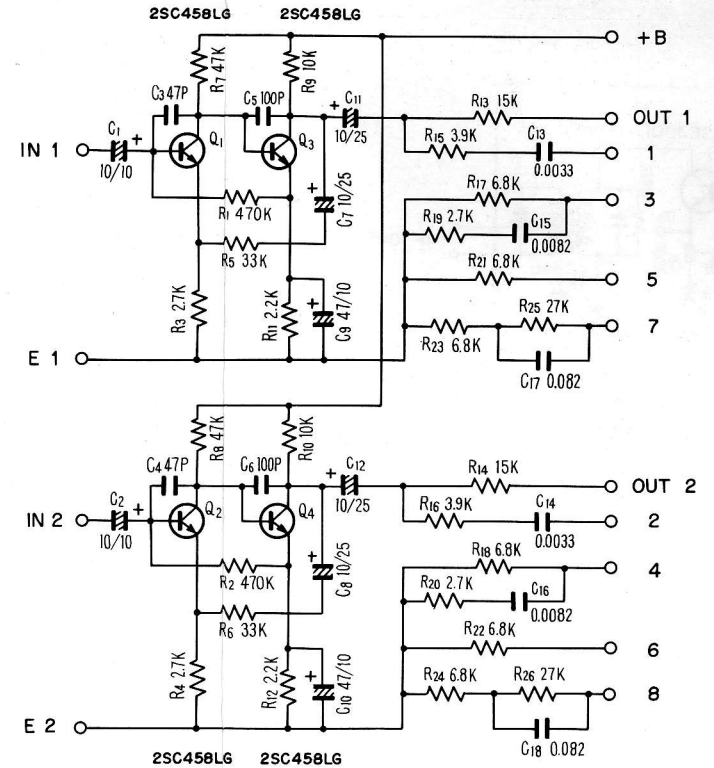

REVERB AMP UNIT

W28 - 002

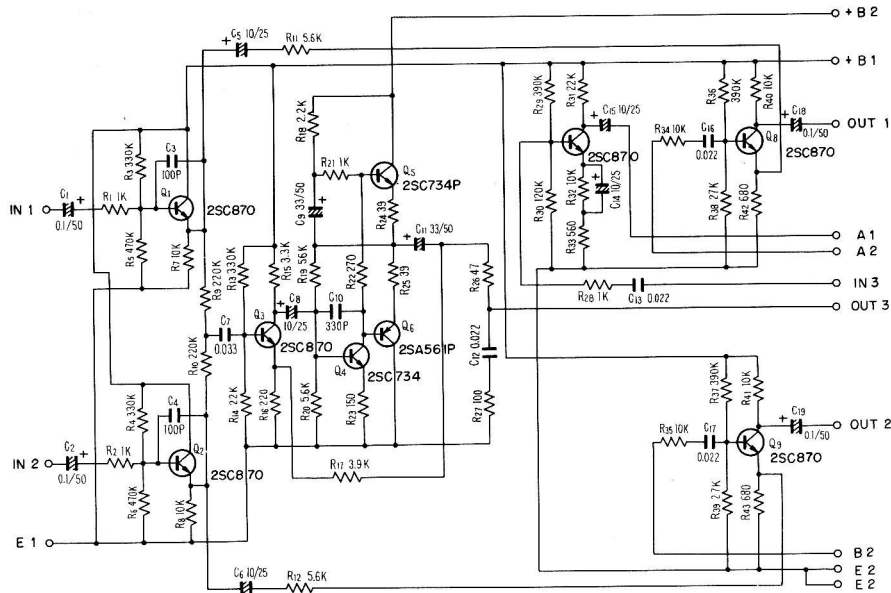

- Q1 2SC870 or 2SC458L
- Q2 2SC870 or 2SC458L
- Q3 2SC870 or 2SC458L
- Q4 2SC734
- Q5 2SC734P or 2SC904
- Q6 2SA561P or 2SA569
- Q7 2SC870 or 2SC458L
- Q8 2SC870 or 2SC458L
- Q9 2SC870 or 2SC458L

MAIN AMP UNIT

W15-052

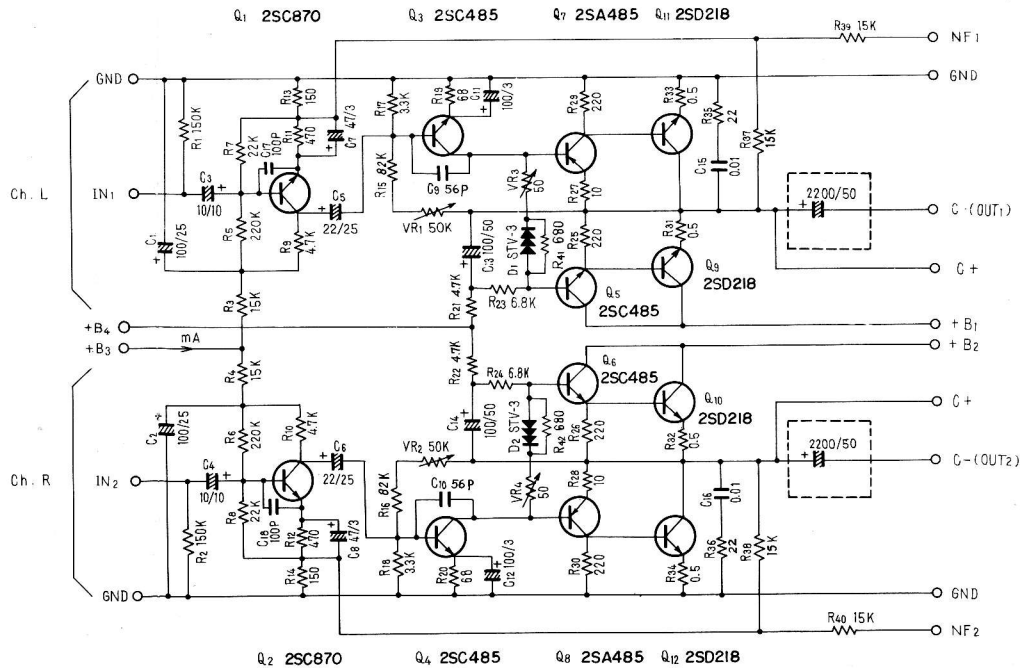

PUSH SWITCH UNIT

W26-003

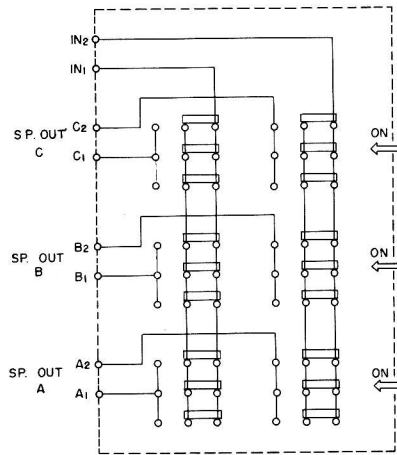

CONTROL AMP UNIT

W22 - 002

